

MUSSIO

ESCAPES

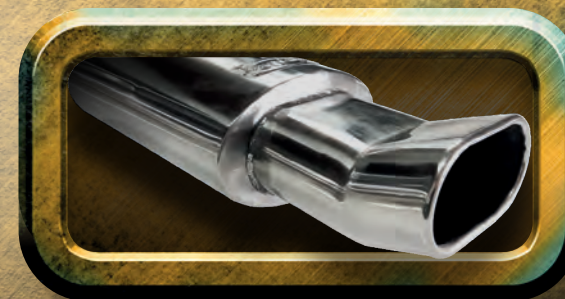

Fábrica de Caños de Escape y Silenciadores



Escapes Originales - Línea Nacional e Importados
Camiones - Mallas Flexibles en Acero Inoxidable

CATALOGO Y LISTA DE PRECIOS

Nº
29

Silenciadores Universales Varios

SILENCIADORES UNIVERSALES (OVALADO 1)

PRECAMARA S/CAÑOS R9-R11-BOQ.1 7/8"

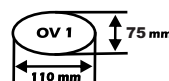
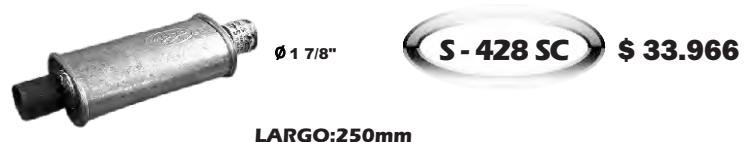

PRECAMARA S/CAÑOS R9-R11-R12 BOO.2"



PRECAMARA - LARGO 400mm BOQ.1 7/8"

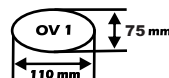

PRECAMARA- LARGO 400mm BOO. 2"



SILENCIADORES UNIVERSALES (REDONDO 1)

SIL DEL. SIN CAÑO LOGAN-SANDERO BOQ. 1 3/4"

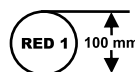

SIL DEL. SIN CAÑO LARGO 400 mm BOO. 1 3/4"



SILENCIADORES UNIVERSALES (OVALADO 2)

SIL R-12 S/CAÑOS BOO. CENTRO DESCENTRADA

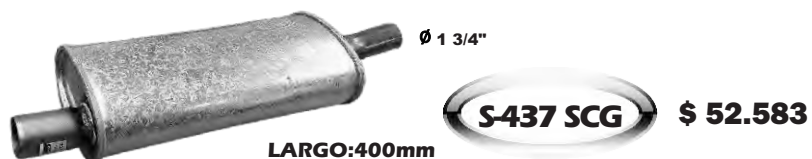

SIL.OV.2 UNIVERSAL REFORMA GAS



SIL. FIAT 1500 BOO. CENTRO Y DESCENTRADA



FIAT QUBO (SIL. SIN CAÑOS) BOO.DESC.



SILENCIADORES UNIVERSALES (OVALADO 4)

SIL UNIV. OV.4 BOO. 1 3/4" DESCENTRADAS

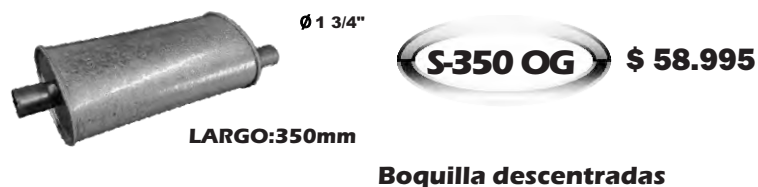

SIL UNIVERSAL OV.4 BOO. 2" DESCENTRADAS



SIL UNIV. OV.4 BOO.DESC. L 550mm 2 1/2"

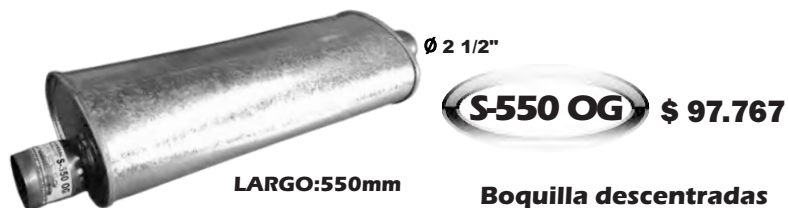

SIL. ECOSPORT KINECTIC SIN CAÑOS BOO.2"



SILENCIADORES UNIVERSALES (OVALADO 4)

FIESTA BRASILEIRO S/CAÑOS

S-306 SCG \$ 55.458



LARGO: 400mm

CHERY TIGGO S/CAÑOS

S-2200 SCG \$ 84.942



LARGO:600mm

Entrada x cuerpo
sale por la tapa

HONDA ACCORD S/CAÑOS

S-2401 SCG \$ 84.645



LARGO:400mm

1 entrada y
2 salidas

SILENCIADORES UNIVERSALES (REDONDO 3)

SIL. GALV. FIAT STRADA REF GAS S/CAÑOS

LARGO:400mm



S-201 SCG \$ 63.288

Boquilla descentradas

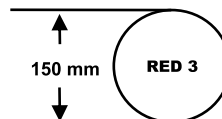

SIL. UNIV. CAMIONES (VACIO)



LARGO:600mm

Boquilla 2 5/8"

S-286 \$ 56.616

REEMPLAZA CATALIZADORES UNIVERSALES

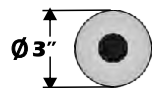

LARGO: 200 mm

RECA-200 134 \$38.853



LARGO: 200 mm

RECA-200 200 \$ 38.853



RE CA MULTIPLE 190 \$102.762

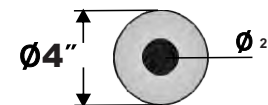

RE CA MULTIPLE 160 \$93.249

SILENCIADORES GALVANIZADOS TAPA CHICA

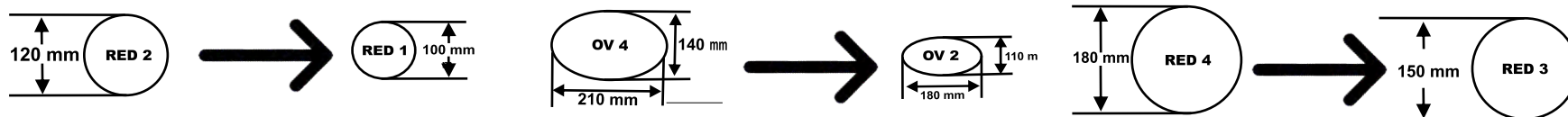

CHEVROLET CORSA 1.6

CHEVROLET AGILE 1.4



CHEVROLET MERIVA 1.8

CHEVROLET ZAFIRA 2.0



CHEVROLET ASTRA 2.0 (SIN BAUL)

CHEVROLET ASTRA 2.0 (CON BAUL)



SILENCIADORES GALVANIZADOS TAPA CHICA

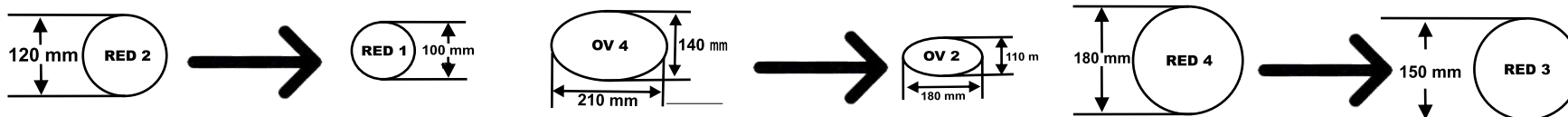

FIAT FIORINO WORKING 1.6



FIAT SIENA 1.6



FORD ECOSPORT 1.6



PEUGEOT 307 1.6 S/BAUL



VOLKSWAGEN GOL POWER



CAÑOS C/ CURVAS A 45 Y 90 GRADOS 1.5m DE LARGO

CAÑO DE 1 3/4" DE 1.5m DE LARGO CON CURVAS A 45 GRADOS



CURVA 45 134

\$ 31.955

CAÑO DE 2" DE 1.5m DE LARGO CON CURVAS A 45 GRADOS



CURVA 45 200

\$ 37.530

CAÑO DE 1 3/4" DE 1.5m DE LARGO CON CURVAS A 90 GRADOS



CURVA 90 134

\$ 31.955

CAÑO DE 2" DE 1.5m DE LARGO CON CURVAS A 90 GRADOS



CURVA 90 200

\$ 37.530

SIL. GALV. C/CAÑO PERFORADO Y LANA DE VIDRIO AMARILLA

Redondos Universales

Chapa Galvanizada

Ovalados Universales

Interior con caño perforado y lana de vidrio amarilla

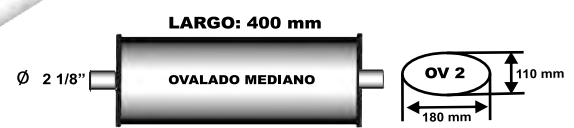
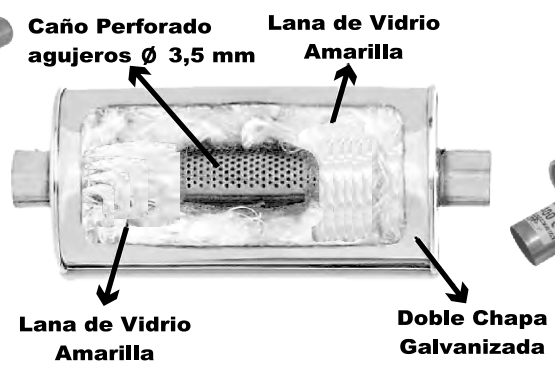

TURBOS de 3" con caño interior Crivado y lana Amarilla con boquillas



TURBOS de 3" con caño interior Perforado y lana Amarilla con boquillas



SILENCIADORES UNIVERSALES PARA CAMIONES - CUPLAS DOBLES

SILENCIADORES UNIVERSALES CAMIONES VACIOS - LARGO 600mm

S-1002 - BOQUILLA 2 1/8" - TAPA 160 mm - LARGO: 600 mm \$ 56.616

S-1003 - BOQUILLA 2 3/8" - TAPA 160 mm - LARGO: 600 mm \$ 56.616

S-286 - BOQUILLA 2 5/8" - TAPA 160 mm - LARGO: 600 mm \$ 56.616

SILENCIADORES UNIVERSALES CAMIONES VACIOS

S-1005 - BOQUILLA 2 5/8" - TAPA 160 mm - LARGO: 900 mm \$ 72.676

S-1006 V - BOQUILLA 3 1/8" - TAPA 220 mm - L 900 mm \$ 84.475

S-1020 - BOQUILLA 2 1/8" - TAPA 160 mm - LARGO: 900 mm \$ 76.112

SILENCIADORES UNIVERSALES CAMIONES LLENOS

S-1005 O - BOQUILLA 2 5/8" - TAPA 220 mm - L 900 mm \$ 88.560

S-1006 O - BOQUILLA 3 1/8" - TAPA 220 mm - L 900 mm \$ 111.510

S-1007 O - BOQUILLA 3 1/2" - TAPA 220 mm - L 900 mm \$ 114.210

S-1008 O - BOQUILLA 4" - TAPA 220 mm - L 900 mm \$ 123.822

S-1020 O - BOQUILLA 2 1/8" - TAPA 220 mm - L 900 mm \$ 97.396

S-1006 OCO - BOQ. 3 1/8" - TAPA 220 mm - L 600 mm \$ 82.188

CUPLAS DOBLES (CON AGRANDE DE 2 LADOS)

C -100 DA - CUPLA DE 4" - 101,60 mm - C/AGRANDE DE 2 LADOS \$ 15.309

C -112 DA - CUPLA DE 4 1/2" - 112 mm - C/AGRANDE DE 2 LADOS \$ 39.102

C -125 DA - CUPLA DE 5" - 125 mm - C/AGRANDE DE 2 LADOS \$ 52.920

CAÑOS RECTOS - CUPLAS

Página 8 - 10

CAÑOS RECTOS (Cortados a 3 m)

CR - 42 - CAÑO DE 1 5/8" - 41,27 mm \$ 46.953

CR - 45 - CAÑO DE 1 3/4" - 44,45 mm \$ 49.950

CR - 48 - CAÑO DE 1 7/8" - 47,62 mm \$ 52.947

CR - 51 - CAÑO DE 2" - 50,80 mm \$ 56.943

CR - 54 - CAÑO DE 2 1/8" - 54,00 mm \$ 60.939

CR - 58 - CAÑO DE 2 1/4" - 57,15 mm \$ 69.930

CR - 64 - CAÑO DE 2 1/2" - 63,50 mm \$ 71.928

CR - 77 - CAÑO DE 3" - 76,20 mm \$ 89.910

CR - 88 - CAÑO DE 3 1/2" - 88,90 mm \$ 129.870

CR - 90 - CAÑO DE 4" - 101,60 mm \$ 174.825

CUPLAS (Largo 150mm a 300mm)

C - 42 - CUPLA DE 1 5/8" - 41,27 mm \$ 4.817

C - 45 - CUPLA DE 1 3/4" - 44,45 mm \$ 5.017

C - 48 - CUPLA DE 1 7/8" - 47,62 mm \$ 5.216

C - 51 - CUPLA DE 2" - 50,80 mm \$ 6.596

C - 58 - CUPLA DE 2 1/4" - 57,15 mm \$ 7.196

C - 64 - CUPLA DE 2 1/2" - 63,50 mm \$ 8.235

C - 77 - CUPLA DE 3" - 76,20 mm \$ 8.694

C - 88 - CUPLA DE 3 1/2" - 88,90 mm \$ 12.312

C - 100 - CUPLA DE 4" - 101,60 mm \$ 15.309

C - 112 - CUPLA DE 4 1/2" - 112 mm \$ 21.560

C - 125 - CUPLA DE 5" - 125 mm \$ 29.400

COLAS Y CURVAS UNIVERSALES - FLEXIBLES CORRUGADOS

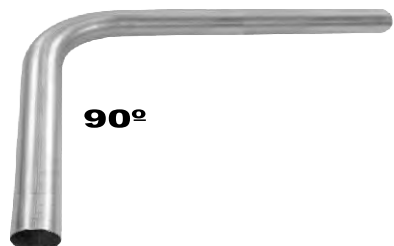

CURVAS 90 °(1000 mm X 1000 mm)

T 1002 - CAÑO 2"	\$ 48.654
T 1003 - CAÑO 2 1/4"	\$ 55.647
T 1004 - CAÑO 2 1/2"	\$ 60.642
T 1005 - CAÑO 3"	\$ 69.633
T 1006 - CAÑO 3 1/2"	\$ 100.143
T 1007 - CAÑO 4"	\$ 127.980
T 4500 - CAÑO 4 1/2"	\$ 174.636
T 5000 - CAÑO 5"	\$ 238.140

CURVAS A 90 (450 mm X 450 mm)

CU - 134 - CAÑO 1 3/4 "	\$ 13.028
CU - 178 - CAÑO 1 7/8 "	\$ 14.027
CU - 200 - CAÑO 2"	\$ 15.125
CU - 214 - CAÑO 2 1/4"	\$ 18.063
CU - 212 - CAÑO 2 1/2"	\$ 20.061
CU - 300 - CAÑO 3"	\$ 22.059
CU - 312 - CAÑO 3 1/2"	\$ 34.587
CU - 400 - CAÑO 4"	\$ 49.275
CU - 412 - CAÑO 4 1/2"	\$ 92.169
CU - 500 - CAÑO 5"	\$ 125.685

CURVAS A 45 °(450 mm X 450 mm)

CU - 134 45 - CAÑO 1 3/4 "	\$ 13.028
CU - 178 45 - CAÑO 1 7/8 "	\$ 14.027
CU - 200 45 - CAÑO 2 "	\$ 15.125
CU - 212 45 - CAÑO 2 1/2"	\$ 20.061
CU - 300 45 - CAÑO 3"	\$ 22.059
CU - 312 45 - CAÑO 3 1/2"	\$ 34.587
CU - 400 45 - CAÑO 4"	\$ 49.275
CU - 412 45 - CAÑO 4 1/2"	\$ 92.169
CU - 500 45 - CAÑO 5"	\$ 125.685

CAÑOS FLEXIBLES CORRUGADOS GALVANIZADOS (FRACCIONADOS X METRO)



F-134 - CORRUGADO DE 1 3/4" - 44,45 mm	\$ 57.355
F-200 - CORRUGADO DE 2" - 50,80 mm	\$ 74.941
F-214 - CORRUGADO DE 2 1/4" - 57,15 mm	\$ 85.534

F-212 - CORRUGADO DE 2 1/2" - 63,50 mm	\$ 98.809
F-300 - CORRUGADO DE 3" - 76,20 mm	\$ 107.271
F-312 - CORRUGADO DE 3 1/2" - 88,90 mm	\$ 120.888
F-400 - CORRUGADO DE 4" - 101,60 mm	\$ 134.564
F-412 - CORRUGADO DE 4 1/2" - 112 mm	\$ 145.540
F-500 - CORRUGADO DE 5" - 125 mm	\$ 172.323



MALLAS DE ACERO INOXIDABLE



MALLAS DE ACERO INOXIDABLE SIN BOQUILLAS

MALLAS (Largo de 100mm sin boquillas)

MA - 100 134INOX SB	\$ 53.920	Largo 100mm 1 3/4"
MA - 100 200INOX SB	\$ 58.178	Largo 100mm 2"
MA - 100 214INOX SB	\$ 70.000	Largo 100mm 2 1/4"
MA - 100 212INOX SB	\$ 74.921	Largo 100mm 2 1/2"
MA - 100 300INOX SB	\$ 118.345	Largo 100mm 3"
MA - 100 312INOX SB	\$ 140.000	Largo 100mm 3 1/2"

MALLAS (Largo de 200mm - 220mm)

MA - 200 134INOX SB	\$ 92.801	Largo 200mm 1 3/4"
MA - 200 200INOX SB	\$ 100.749	Largo 200mm 2"

MALLAS (Largo de 150mm a 250 sin boquillas)

MA - 220 214INOX SB	\$ 130.000	Largo 220mm 2 1/4"
MA - 200 212INOX SB	\$ 126.861	Largo 200mm 2 1/2"
MA - 150 300INOX SB	\$ 147.294	Largo 150mm 3"
MA - 200 312INOX SB	\$ 248.332	Largo 200mm 3 1/2"
MA - 250 400INOX SB	\$ 374.625	Largo 250mm 4"
MA - 200 412INOX SB	\$ 505.175	Largo 200mm 4 1/2"
MA - 200 500INOX SB	\$ 539.235	Largo 200mm 5"



MALLAS DE ACERO INOXIDABLE CON BOQUILLAS



MALLAS (Largo de 100mm con boquillas)

MA - 100 134INOX CB	\$ 72.368	Largo 100mm 1 3/4"
MA - 100 200INOX CB	\$ 78.327	Largo 100mm 2"

MALLAS (Largo de 200mm con boquillas)

MA - 200 134INOX CB	\$ 111.250	Largo 200mm 1 3/4"
MA - 200 200INOX CB	\$ 117.958	Largo 200mm 2"



CITROËN



CHEVROLET

VEHICULO

PÁGINA

CITROËN

C3 - C3 PICASSO	1
XSARA - PICASSO - BERLINGO	2
BERLINGO - C4	3

CHEVROLET

CHEVY - SUPER	4
PICK UPS	5/8
MONZA - ASTRA	9/10
ZAFIRA - MERIVA - CHEVETTE	11
CORSA - CORSA PICK UP	12
CORSA 1.8 - AGILE	13
VECTRA	14
FUN - CELTA - MONTANA	15
AVEO - ONIX - PRISMA - SPIN	16
CRUZE - TRACKER	17



PROFESSIONAL ESCAPES



CITROËN C3 1.6 16V (2001 - 2013) - Diesel Hdi (2003-2009)

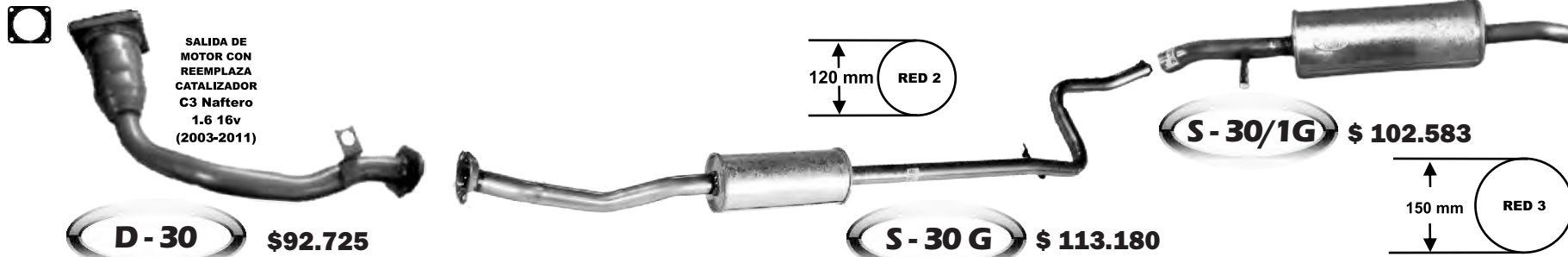

CITROËN C3 PICASSO 1.6 NAFTERO Y C3 AIRCROSS (10-21)



CITROËN C3 1.5 8V (2013 - 2016) - 1.6 16V (2013-2022)



CITROEN XSARA 1.8 i 16V (1999-2000)



CITROEN PICASSO NAF. 2.0 16V (01-10) - HdI 1.9 90 CV (97-05)



CITROEN BERLINGO - NAF. 1.4 i (98 - 10) = PEUGEOT PARTNER

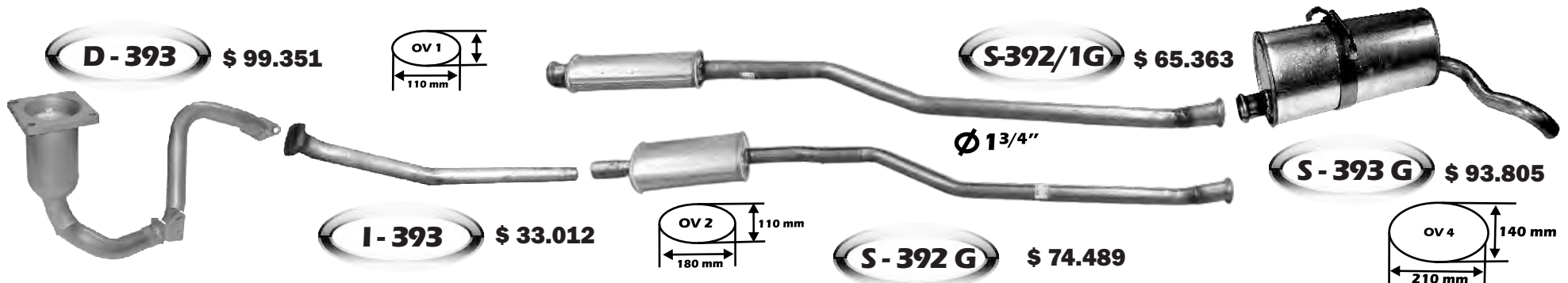

CITROËN BERLINGO - Diesel 1.9 (1998 - 2010)



CITROËN C4 1.6 I 16V - 110CV (2008-2015)

* Este articulo es = al P.307
1.6 (sin baul) bicuerpo

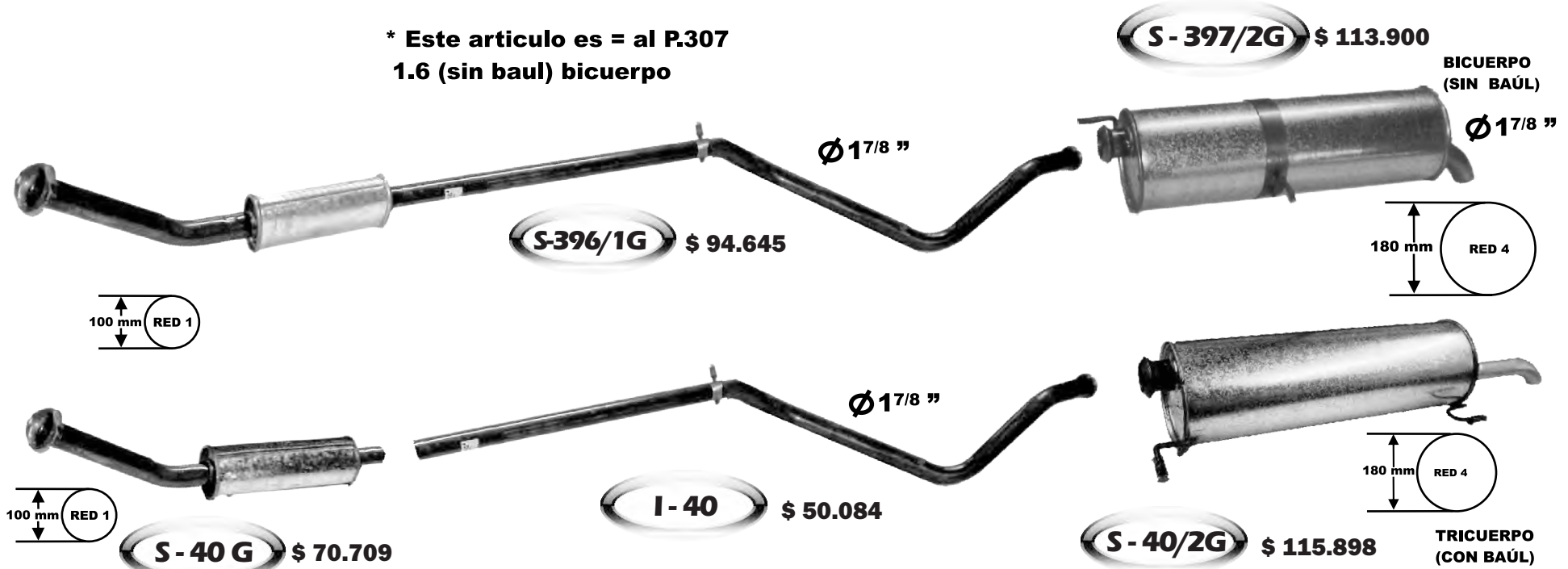



CHEVROLET SUPER (1966 - 1974)



D-62 \$ 57.354



T-64 \$ 39.566



CHEVY (1966 - 1974)



D-80 \$ 70.068

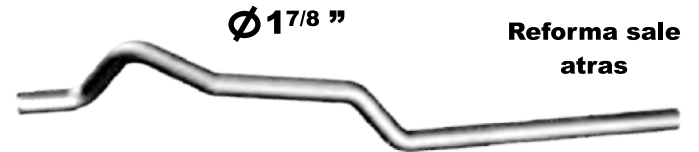

T-85/1 \$ 42.266



CHEVY SERIE (1973 - 1978)



D-85 \$ 67.368



T-85 \$ 41.167



CHEVROLET PICK UP (1960 - 1965)

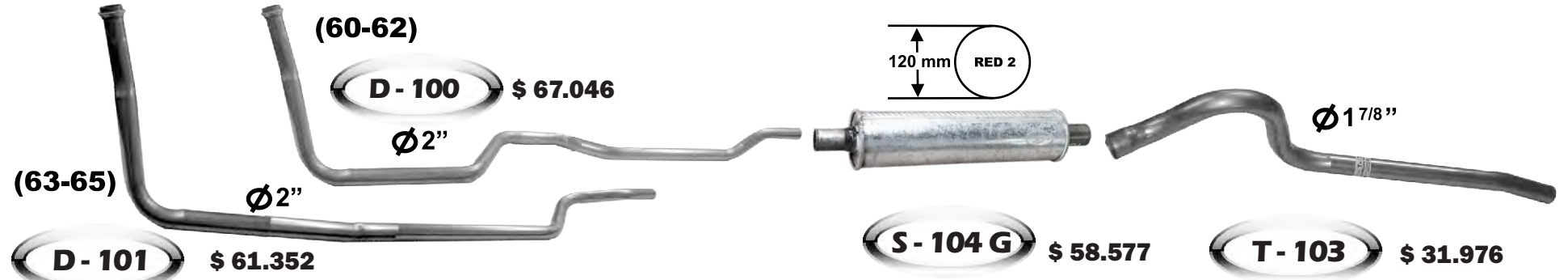

CHEVROLET PICK UP (1966 - 1972)

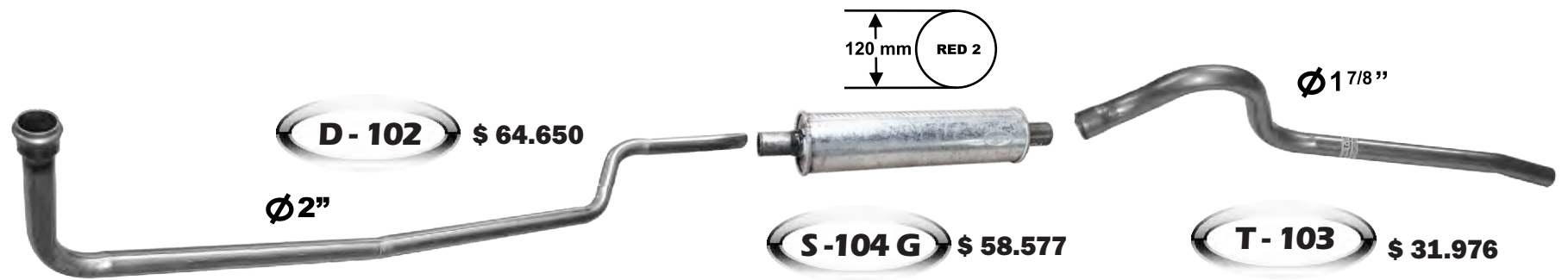

CHEVROLET PICK UP (1973 - 1978)





CHEVROLET



CHEVROLET PICK UP REFORMA A GAS (1973 - 1978)

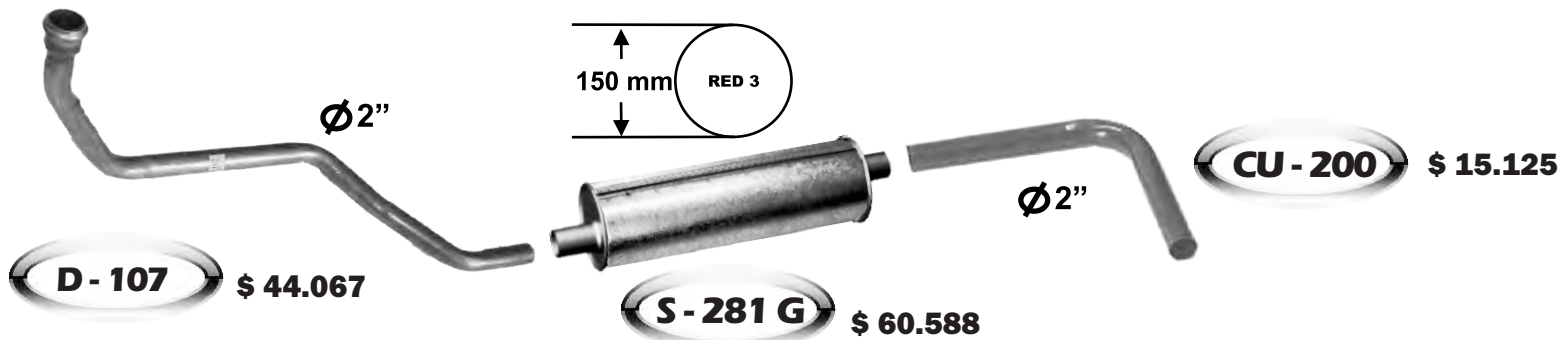

CHEVROLET PICK UP C-20 (1993 - 1996) (Brida Fija 3 agujeros)

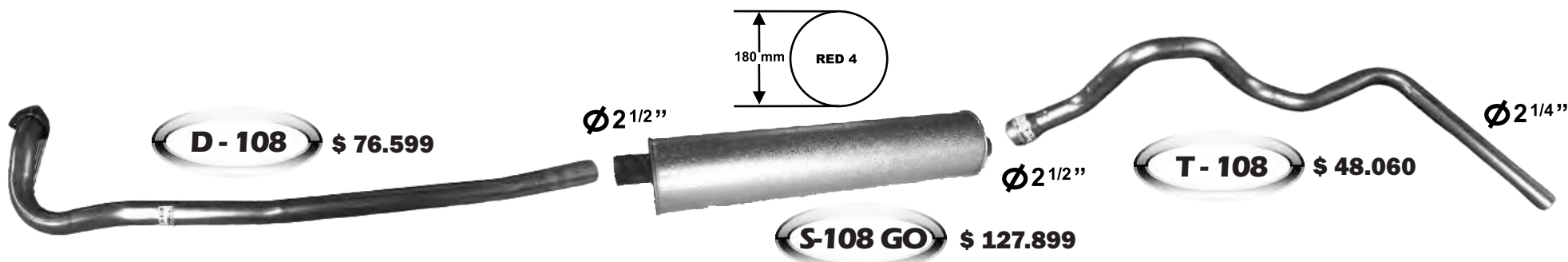

CHEVROLET PICK UP D-20 (1993 - 1996)

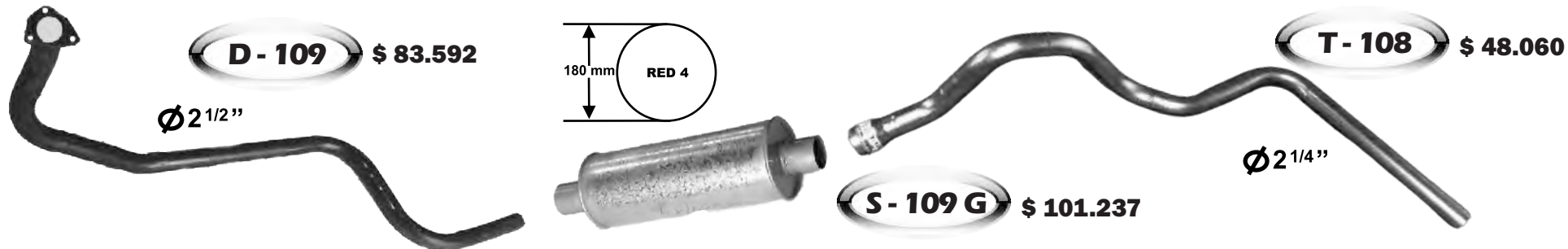



CHEVROLET PICK UP SILVERADO MAXION (1997 - 2002)

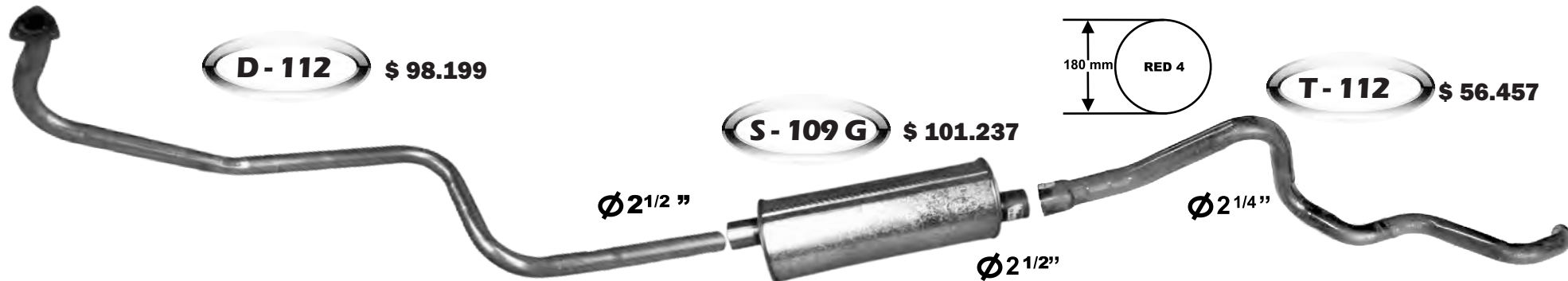

CHEVROLET PICK UP SILVERADO MWM TD 4.2 (97->)



CHEVROLET LUV - ISUZU Diesel 2.5 (1995 - 1999)

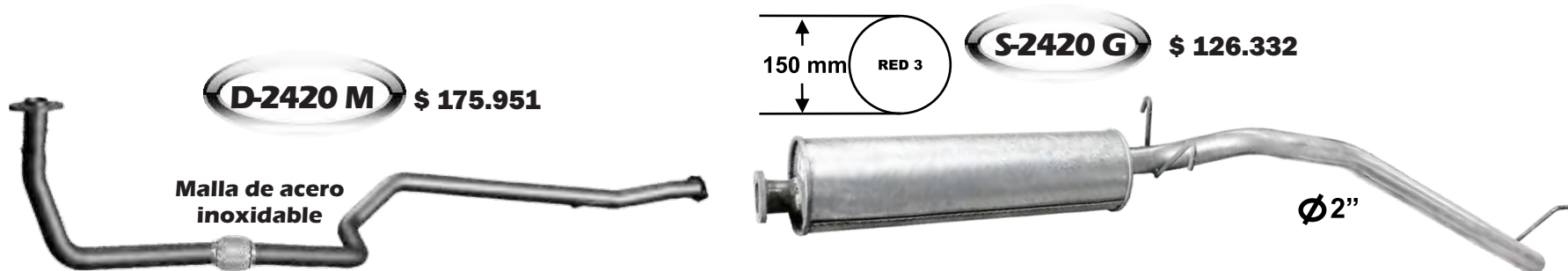



CHEVROLET PICK UP S - 10 Diesel (CAB. DOBLE hasta 1997)

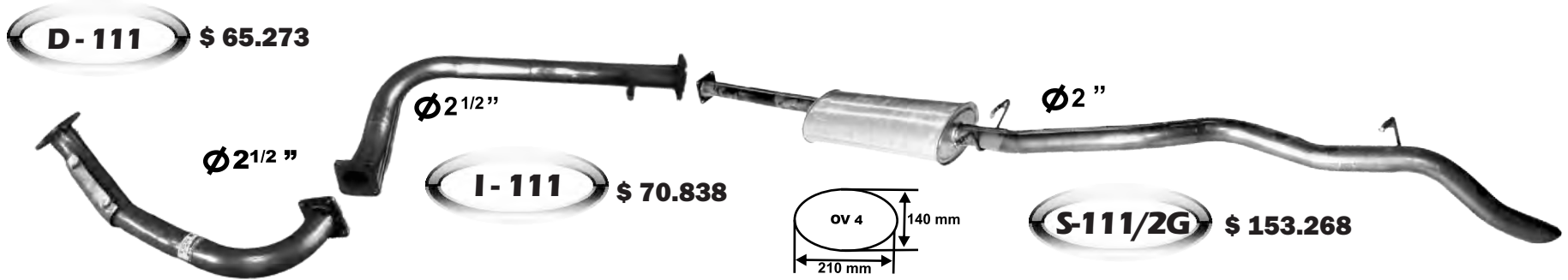

CHEVROLET S-10 - 2.8 TD CAB. DOBLE (2001 - 2013)



CHEVROLET BLAZER 2.5 TURBO DIESEL (1997-2000)

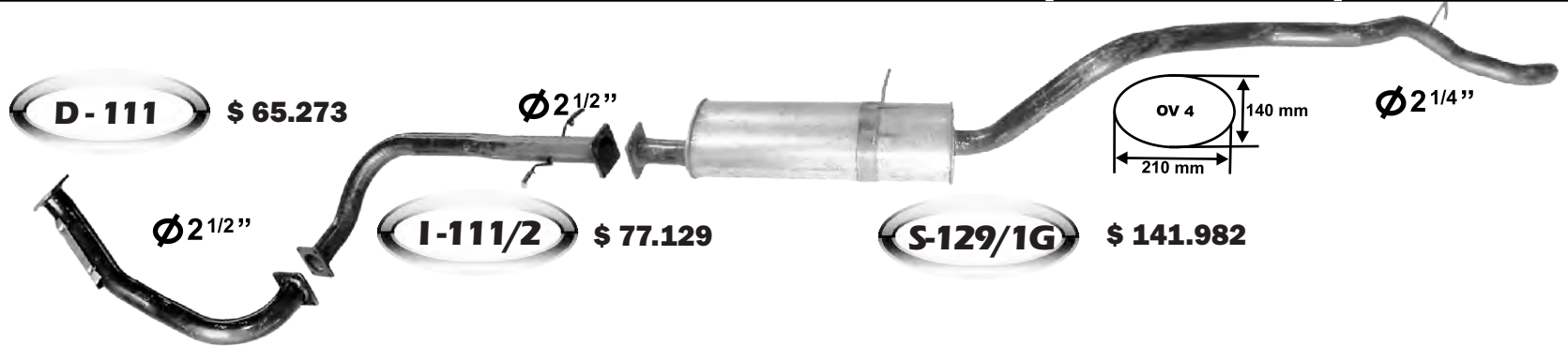



CHEVROLET BLAZER NAF. 2.2 MPFI (1995 - 2000)

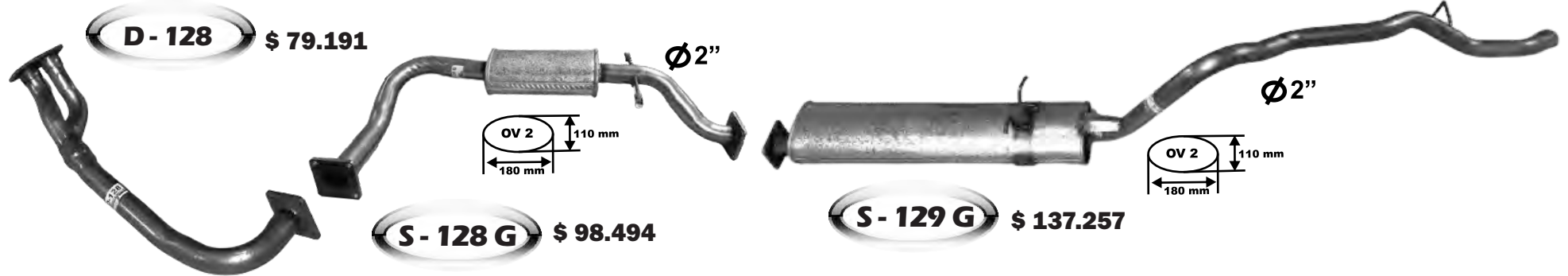

CHEVROLET MONZA 1.8 - 2.0 (1991 - 1996)

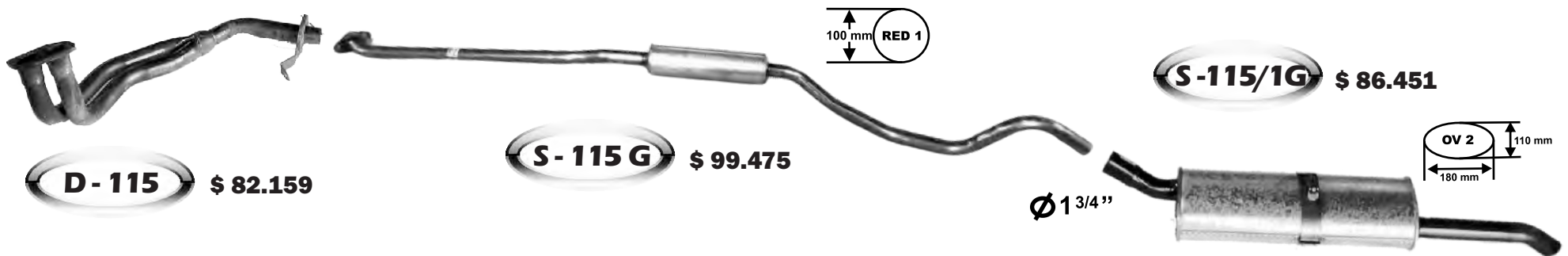

CHEVROLET ASTRA GLS 1.8 - 2.0 8V (CON BAUL) (1999-2004)

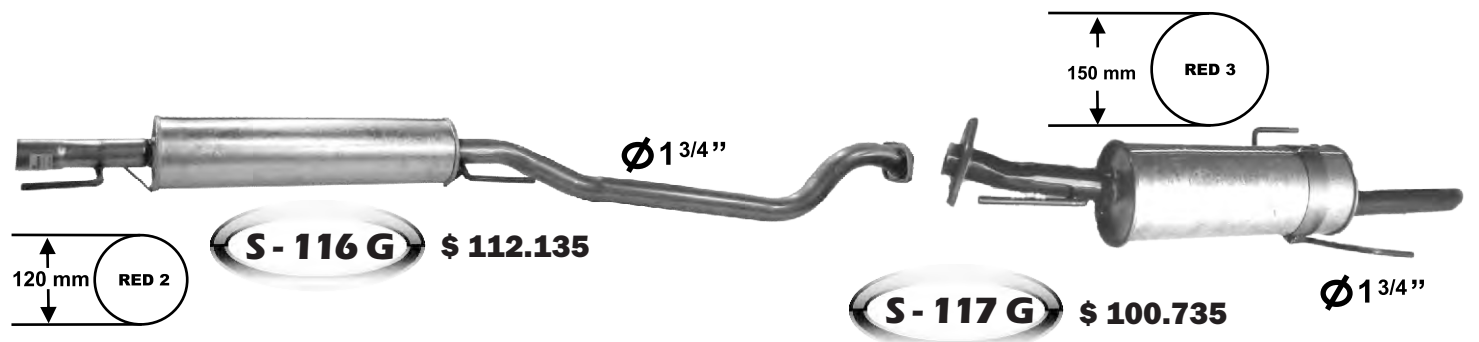



CHEVROLET



CHEVROLET ASTRA 2.0-2.4 16V CD-ASTRA II (SIN BAUL) (00-06)

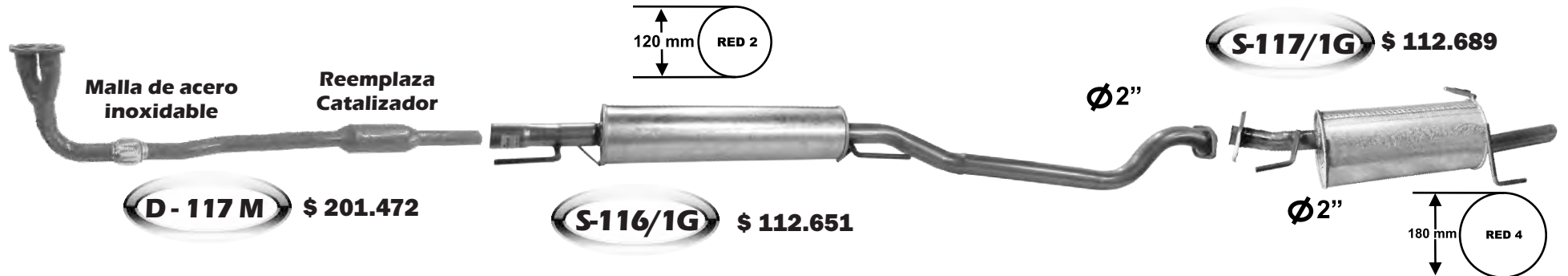

CHEVROLET ASTRA 2.0-2.4 16V CD-ASTRA II (CON BAUL) (99-06)

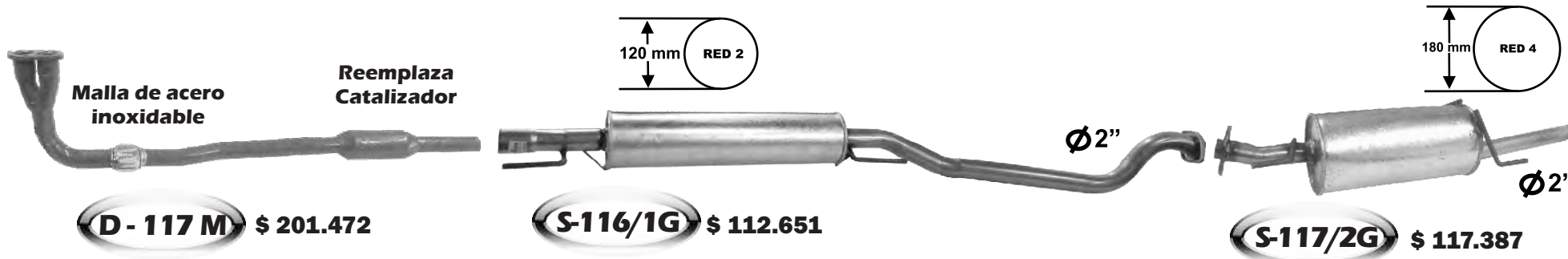

CHEVROLET ASTRA 2.4 GSI - 16V (CON BAUL) (05-09)

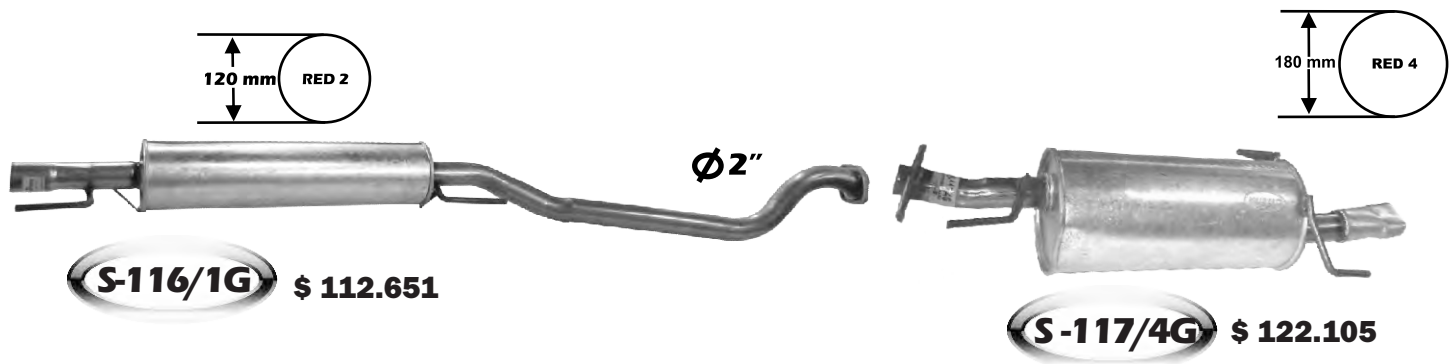



CHEVROLET ZAFIRA 2.0 8V - 16V (2001 - 2011)



CHEVROLET MERIVA 1.8 8V (2003 - 2013) - 16V (2003-2006)



CHEVETTE Y GMC 500 (1992 - 1993)

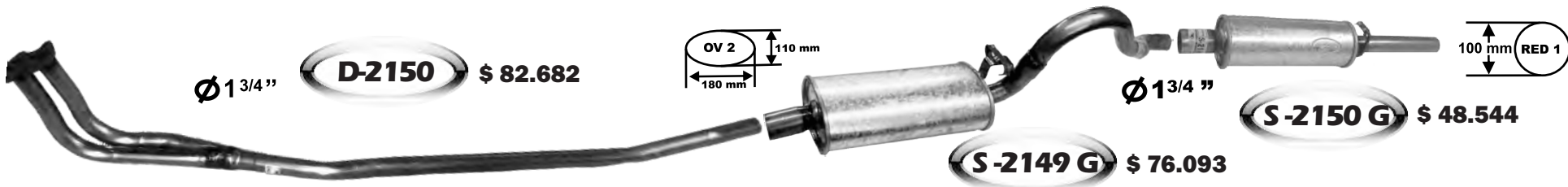



CHEVROLET CORSA 1.6 8V (1995 - 2008) - (SIN BAUL)

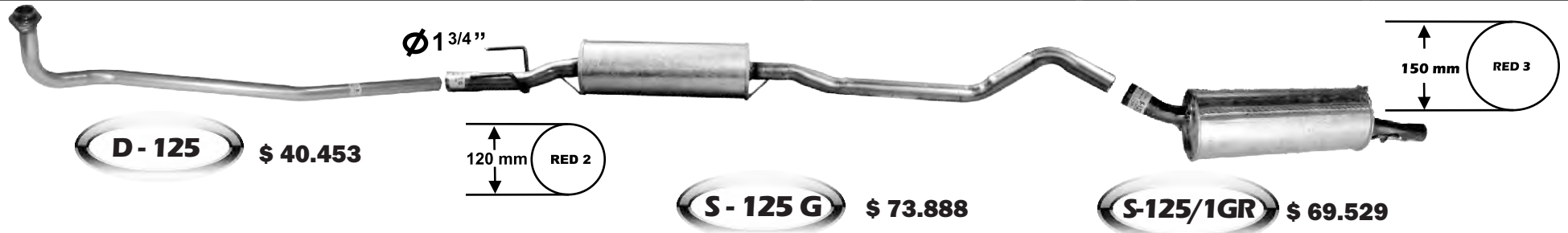

CHEVROLET CORSA 1.6 8V (1995 - 2009) - (CON BAUL)

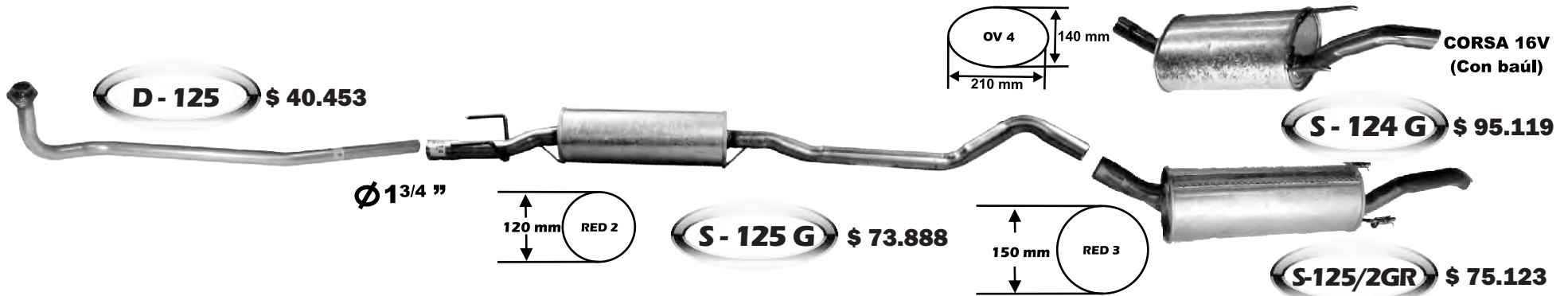

CHEVROLET CORSA PICK UP 1.7 DIESEL (1998-2003)





CHEVROLET CORSA 1.8 i (Sin Baul) (2002-2011)



CHEVROLET CORSA 1.8 i (Con Baul) (2002-2011)



CHEVROLET AGILE 1.4 (2009 - 2017)

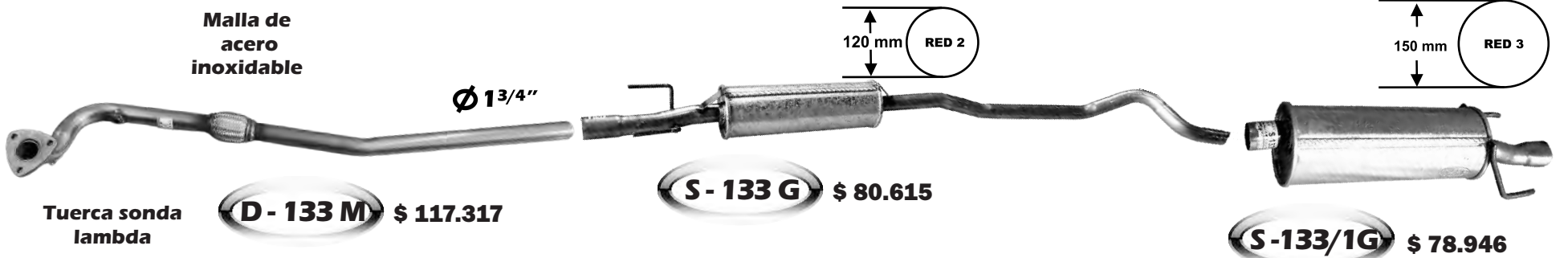



CHEVROLET VECTRA 2.0 GT GLS (Sin Baul) (2007 - 2011)

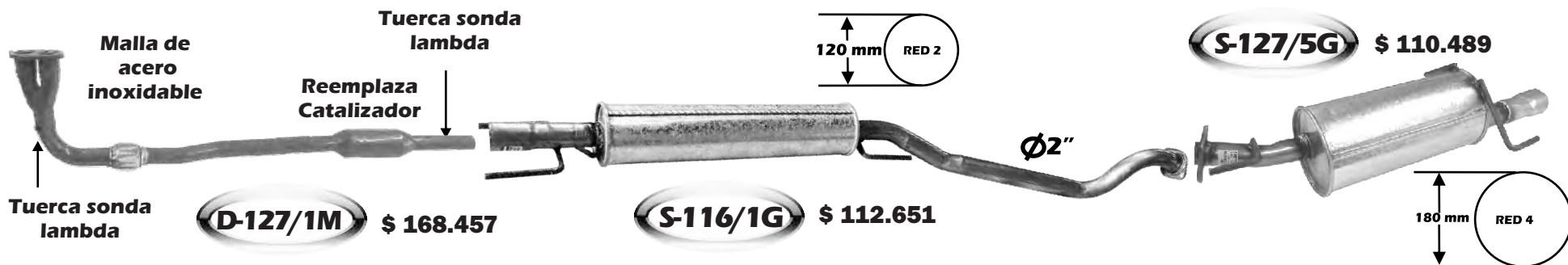

CHEVROLET VECTRA 2.4 16V 4 Ptas. (Con Baul) (2007-2011)

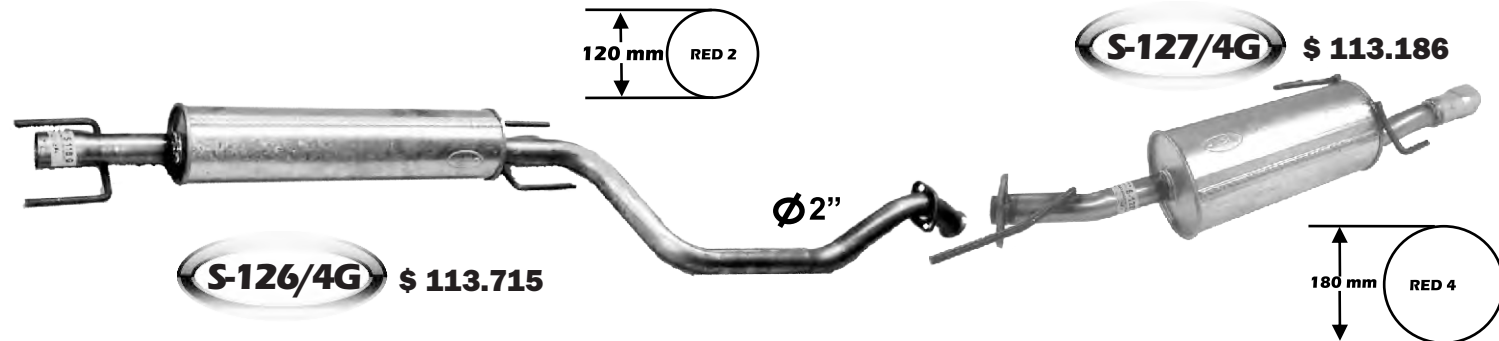

CHEVROLET VECTRA 2.0 (1997 - 2003) - 2.2 CD 16V (03-06)





SUZUKI FUN 1.0 (2003-2006) - 1.4 (2004 - 2006)

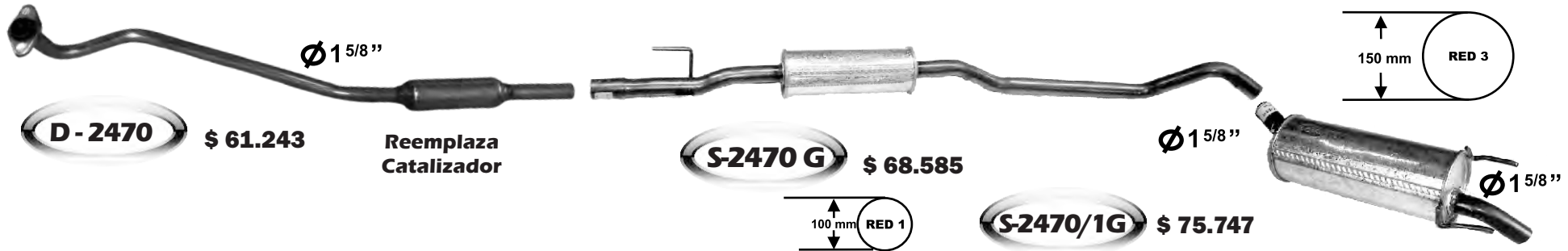

CHEVROLET CORSA - CELTA - SUZUKI FUN 1.4 (2004-2011)

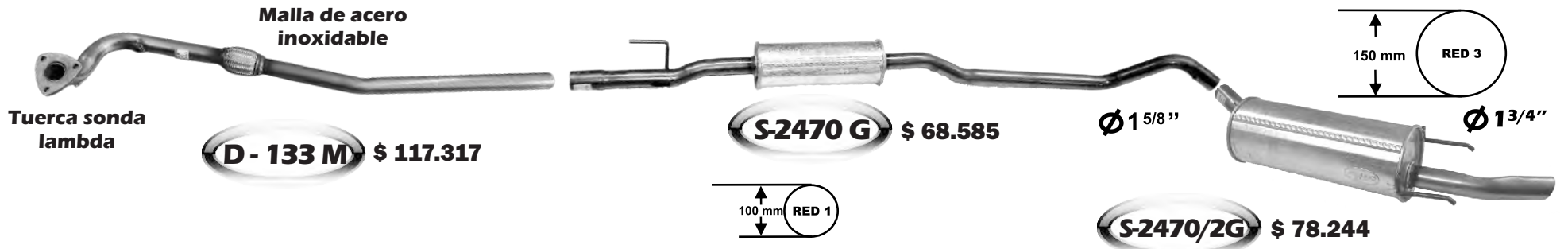

CHEVROLET MONTANA 1.8 (2011 - 2020)

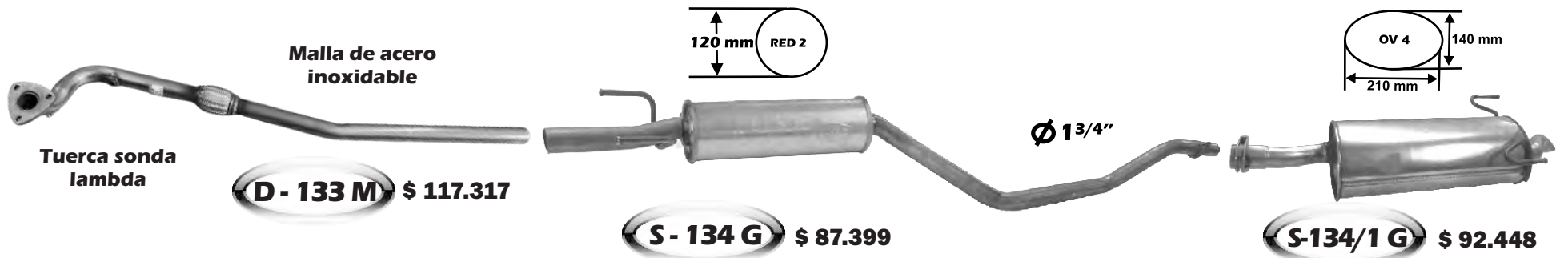



CHEVROLET AVEO 1.6 (2008-2014)



Reemplaza catalizador Motor E- Tech II 16V

RE-CA114

\$134.911

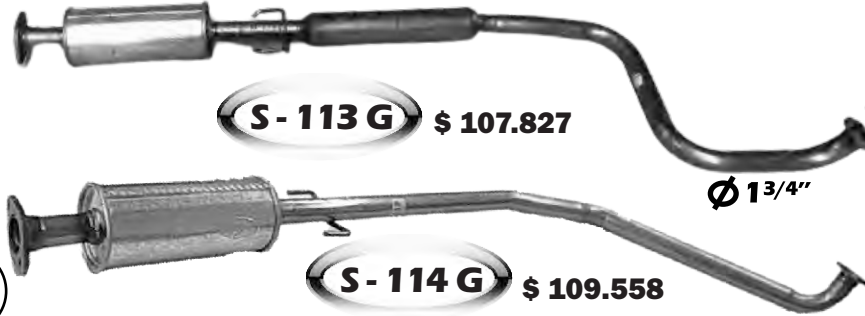
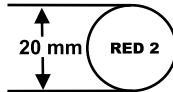

S-113 G

\$ 107.827

Ø 1 3/4"



S-114 G

\$ 109.558



S-114/1G

\$ 114.065



CHEVROLET PRISMA - ONIX 1.4 (2013 - 2021)



Tuerca sonda lambda

Malla de acero inoxidable

I-155 M

\$ 131.097

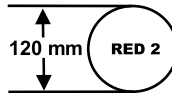

S-139 G

\$ 97.447



S-140/1G

\$ 96.729



CHEVROLET SPIN 1.8 (2012->)



Malla de acero inoxidable



Tuerca sonda lambda

I-155 M

\$ 131.097



S-155 G

\$ 66.849

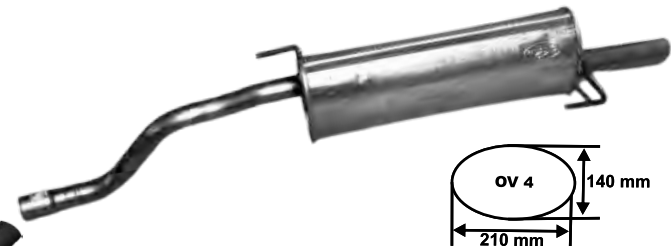

S-155/1G

\$ 104.601



CHEVROLET CRUZE 1.8 (2010-2015) (SIN BAUL)

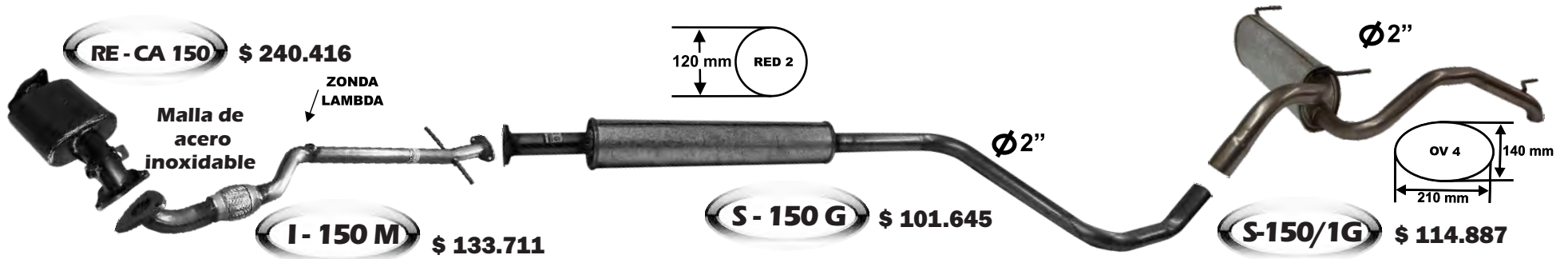

CHEVROLET CRUZE 1.8 (2010-2015) (CON BAUL)

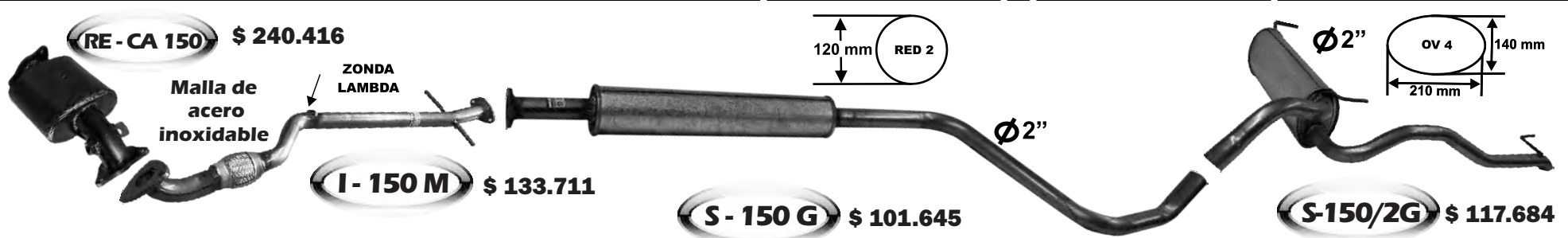

CHEVROLET TRACKER 1.8 (2012-2020)

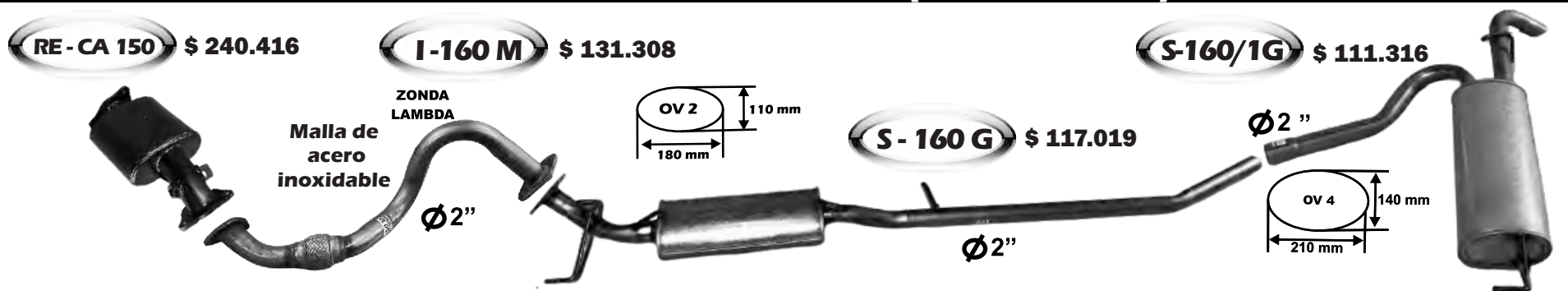



VEHICULO

PÁGINA

QUBO - STYLO - STRADA	1
DUCATO - IDEA 1.4	2
IDEA 1.8 - PUNTO 1.4 - 1.8	3
125 - 128 - TIPO	4
DUNA - DUNA WEEKEND	5/6
UNO	7
147 VIVACE - SPAZIO	8
FIORINO	9
REGATTA - PALIO WEEKEND 1.4	10/11/12
SIENA	13
CRONOS - DOBLO	14





FIAT

FIAT QUBO

FIAT STYLO 1.8 8V (2005-2011)

FIAT



FIAT

FIAT STRADA 1.8 (2004 - 2010)

FIAT

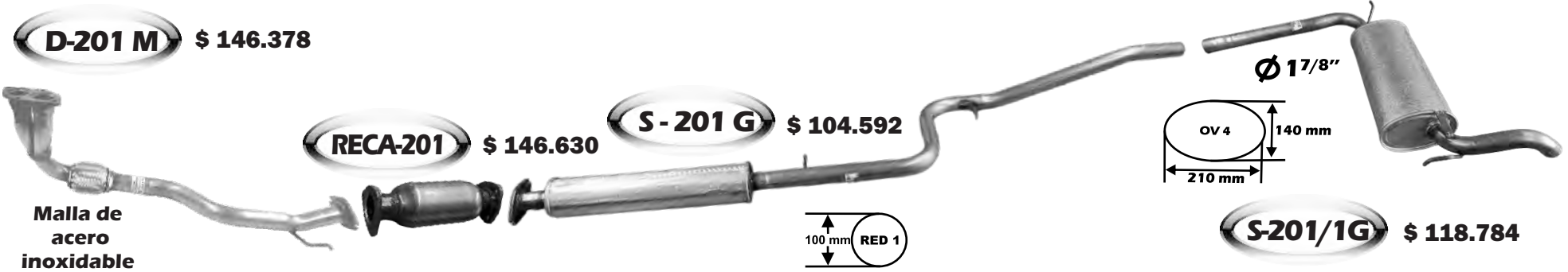

FIAT

FIAT STRADA 1.4 (2009-2020)

FIAT

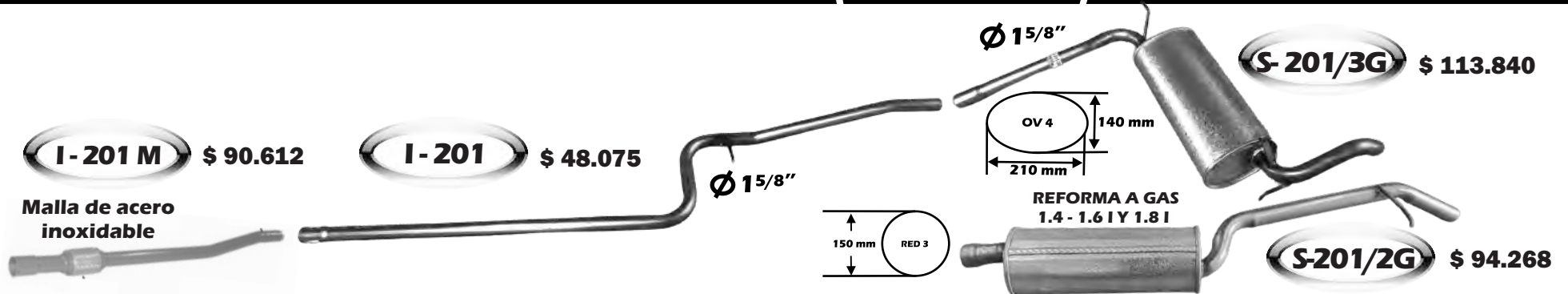



FIAT

FIAT DUCATO DIESEL 2.5 (1997-1999)-DIESEL 2.8 (2000 - 2004) FIAT

FIAT

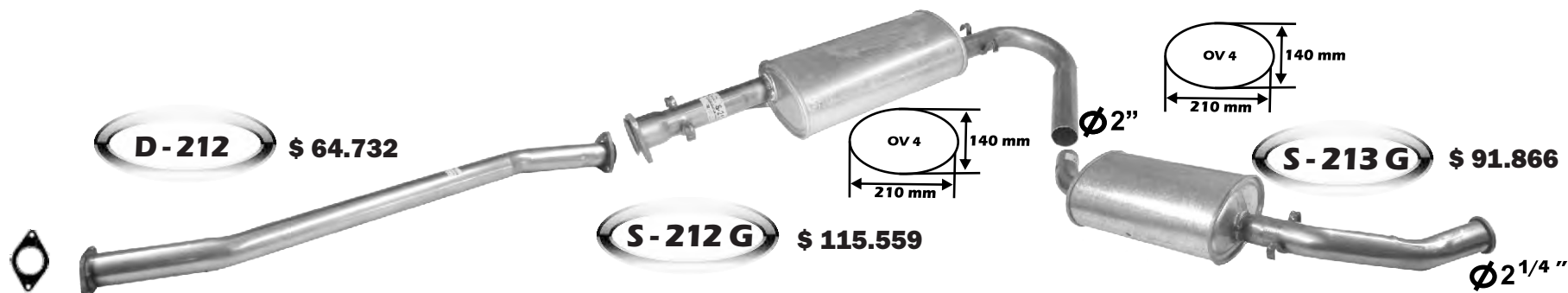

FIAT

FIAT DUCATO DIESEL JTD 2.8 - BOXER (2007->) FIAT

FIAT

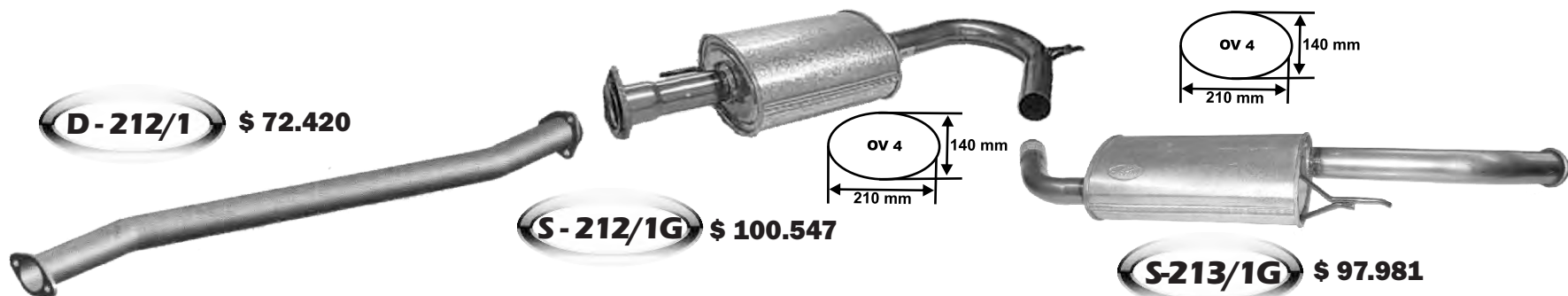

FIAT

FIAT IDEA 1.4 8V - 82CV (2007-2011) FIAT

FIAT

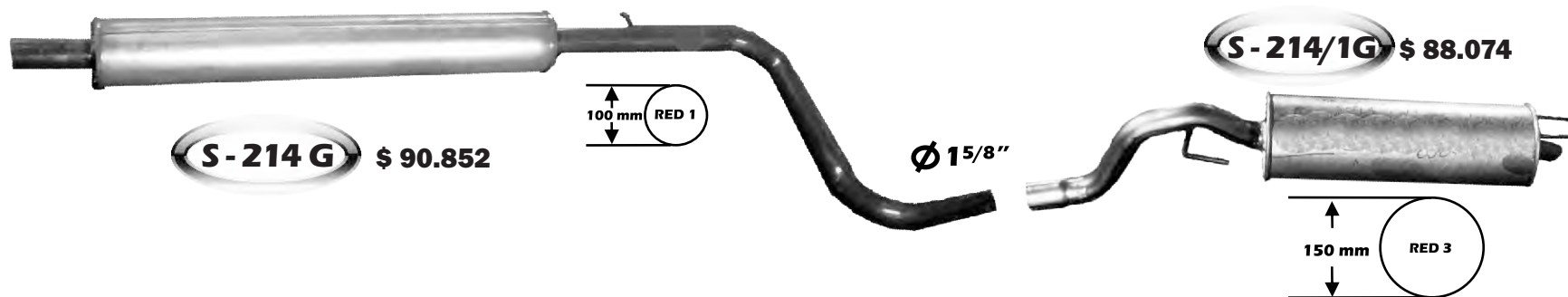



FIAT

FIAT IDEA 1.8 (2005-2010)

FIAT

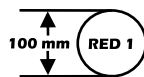

S-215 G \$ 91.927



Ø 1 7/8"



S-215/1G \$ 91.071

FIAT

FIAT PUNTO 1.4 (2007-2018)

FIAT

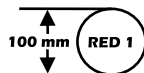

S-218 G \$ 81.348

Ø 1 5/8"

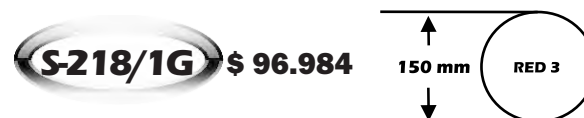

S-218/1G \$ 96.984

FIAT

FIAT PUNTO 1.8 (2007-2011)

FIAT

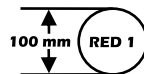

S-219 G \$ 85.344

Ø 1 7/8"

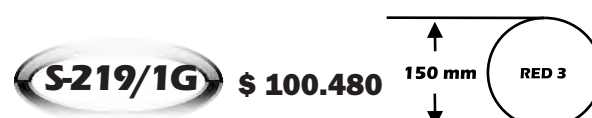

S-219/1G \$ 100.480



FIAT

FIAT 128 1.1 - 1.3 (1971-1991)

FIAT

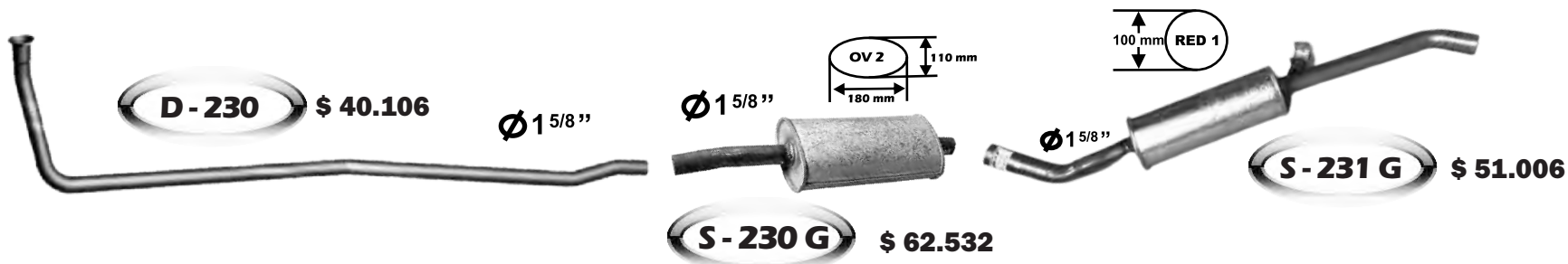

FIAT

FIAT TIPO 1.6 (1994 - 1997)

FIAT

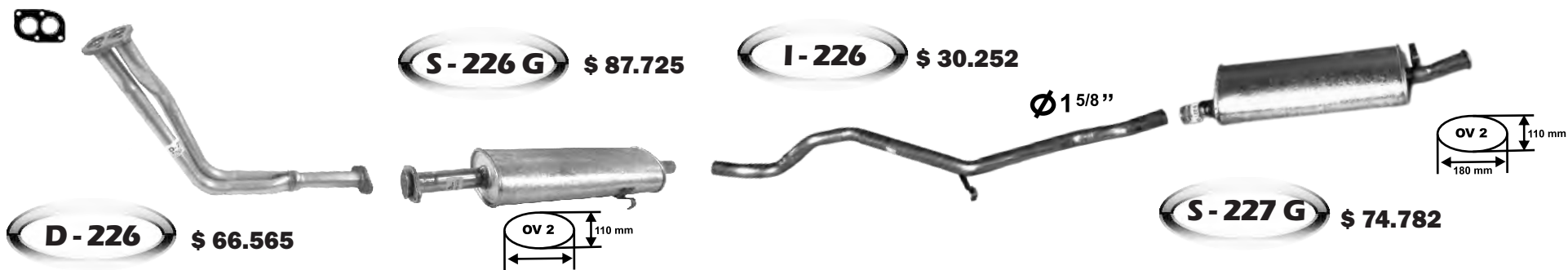

FIAT

FIAT 125

FIAT TIPO 1.4 - 1.6 INYECCION

FIAT

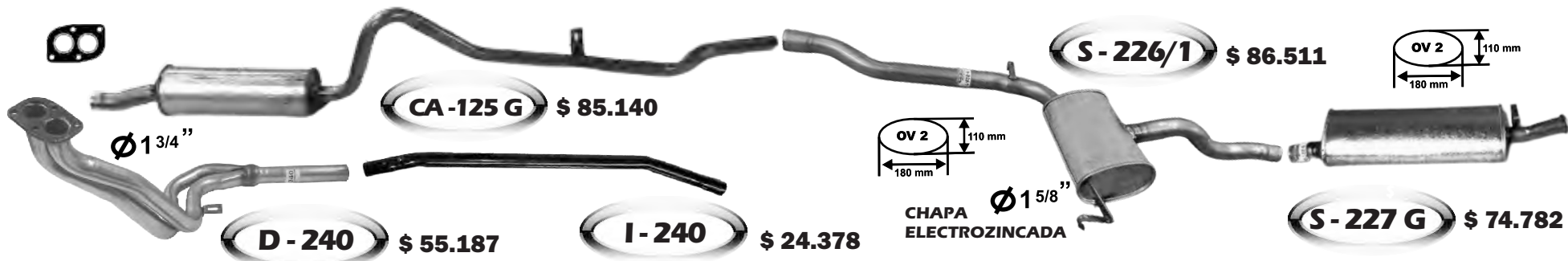



FIAT

FIAT DUNA WEEKEND - TIPO 1.6 (1991-1995)

FIAT

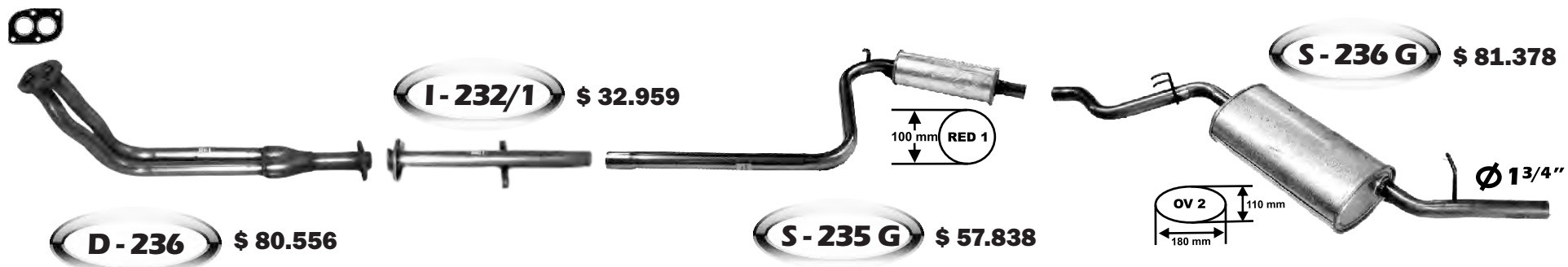

FIAT

FIAT DUNA 1.5 - 1.6 - TIPO 1.4 (1988 - 1997)

FIAT



FIAT

FIAT DUNA 1.6 SL (NAFTERO BRASILEIRO)

FIAT

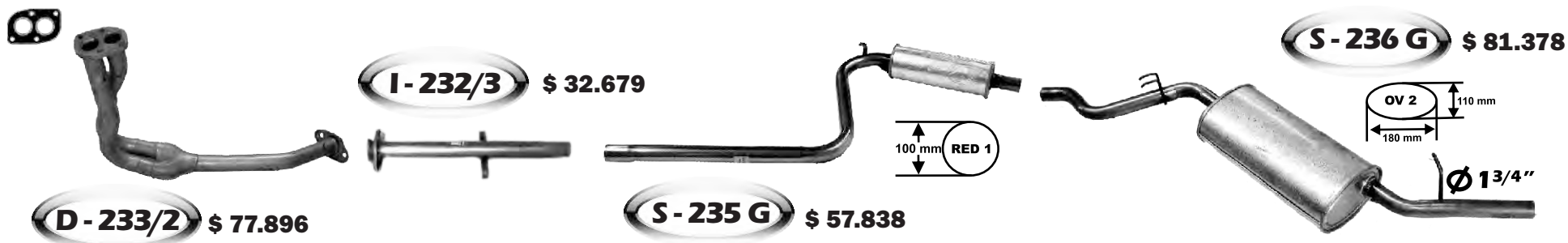



FIAT

FIAT DUNA WEEKEND Diesel 1.7 (1992-1997)

FIAT

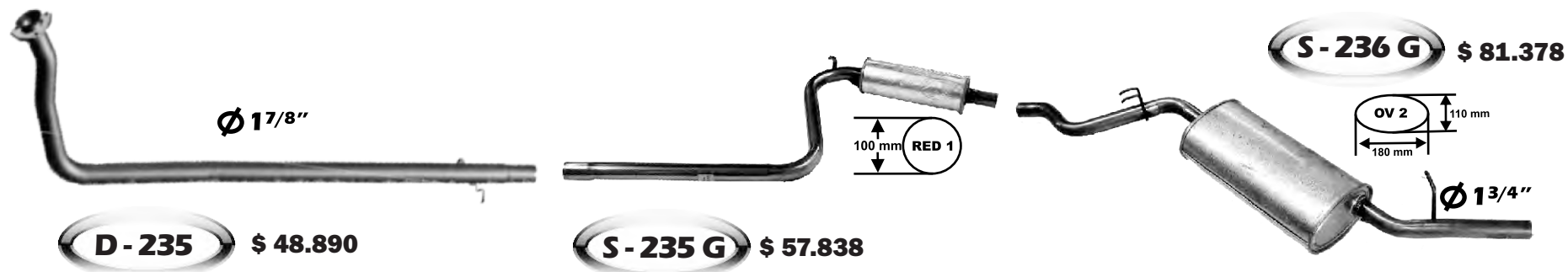

FIAT

FIAT DUNA 1.3 NAFTERO (1988-1990)

FIAT

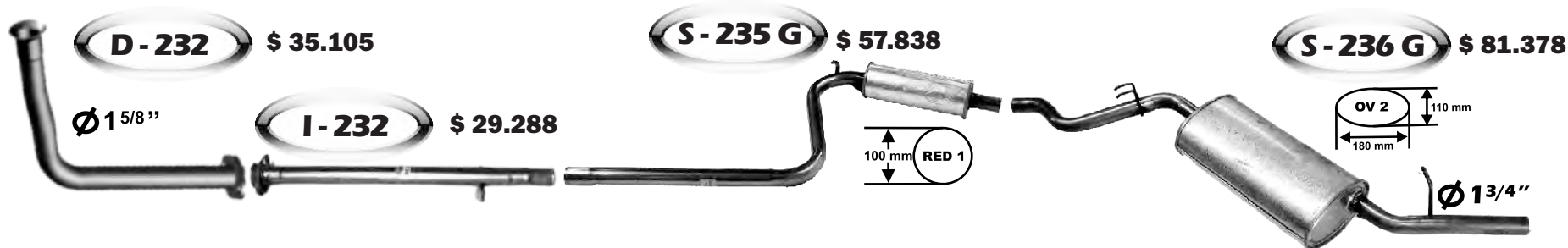

FIAT

FIAT DUNA WEEKEND 1.3 Diesel (1991-1996)

FIAT





FIAT

FIAT UNO FIRE 1.3 8v-16v (2004-2015)

FIAT

D - 253/2 \$ 116.299

FIRE 1.3i 8v
(2003-2015)

Reemplaza
Catalizador



ZONDA
LAMBDA

S-235/3G \$ 83.919

Ø 1 5/8"

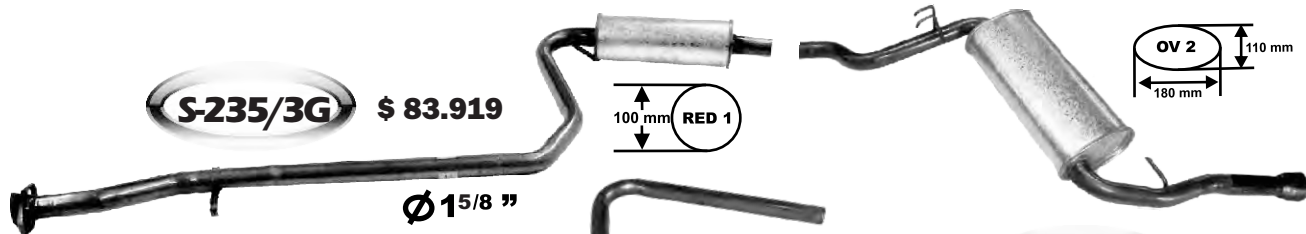

100 mm
RED 1

OV 2
110 mm
180 mm

S-238/3G \$ 76.240

FIRE 1.3 16v
(2001-2006)

MALLA DE ACERO
INOXIDABLE

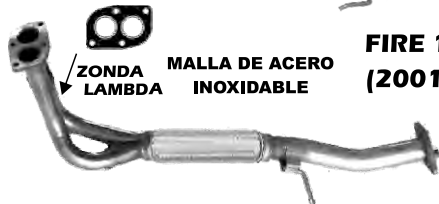

ZONDA
LAMBDA

D - 253 M \$ 207.437

Ø 1 5/8"

I - 235/3 \$ 54.921

FIAT

FIAT UNO TIPO 1.5 - TIPO 1.6 (1988 - 1998)

FIAT

D - 233 \$ 60.713



I - 232 \$ 29.288

S - 235 G \$ 57.838

100 mm
RED 1

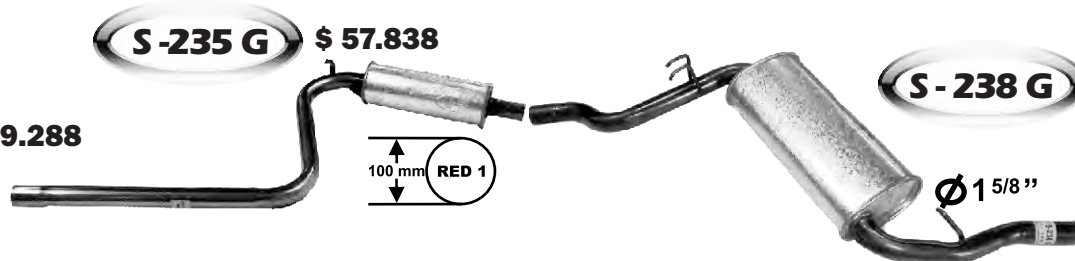

S - 238 G \$ 76.726

Ø 1 5/8"

OV 2
110 mm
180 mm

FIAT

FIAT UNO TIPO 1.4 SL - 1.5 - 1.6 SCR

FIAT

I - 232 \$ 29.288



100 mm
RED 1



T - 238 \$ 36.924

Ø 2"

D - 233 \$ 60.713

S - 235 G \$ 57.838

T-238 212 \$ 46.698

Ø 2 1/2"



FIAT

FIAT 147 FIORINO TIPO 1.4 (1992 - 1997)

FIAT



FIAT

FIAT 147 - VIVACE y SPAZIO Diesel 1.3 (1985 - 1996)

FIAT



FIAT

FIAT 147 - TIPO 1.4 (1990 - 1996)

FIAT





FIAT

FIAT FIORINO WORKING 1.3 FIRE(04-15) - 1.7 Diesel (98 - 07)

FIAT

D - 253/2 \$ 116.299
Reemplaza Catalizador

I - 237 \$ 33.759

S - 237 G \$ 63.072

S-237/1G \$ 88.768

S-235/3G \$ 83.919

FIAT UNO FIRE 1.3 (2004-2015)

REFORMA A GAS Ø 1 5/8"

Malla de acero inoxidable
1.7 TD (2004-2007)

D - 237 M \$ 118.931

I - 237/1 \$ 43.161

S-237/2G \$ 68.148

Dimensions: OV 2 (180 mm), OV 4 (210 mm), 140 mm, 110 mm, 100 mm, RED 1

FIAT

FIAT FIORINO 1.4 FIRE(2014->)

FIAT

D - 201/1M \$ 139.520
Malla de acero inoxidable
Ø 1 3/4"

S - 201/4G \$ 74.654

S-201/3G \$ 113.840
FIRE 1.4

REFORMA A GAS Ø 1 5/8"

S-237/2G \$ 68.148

Dimensions: OV 2 (180 mm), OV 4 (210 mm), 140 mm, 110 mm, 100 mm, RED 1



FIAT

FIAT REGATTA 85 1.5 (1985 - 1990)

FIAT



FIAT

FIAT REGATTA TIPO 1.6 (1990 - 1995)

FIAT



FIAT

FIAT PALIO WEEKEND 1.4 FIRE (2009 - 2015)

FIAT





FIAT

FIAT PALIO FIRE 1.3 (2001 - 2006)

FIAT

Tuerca sonda lambda
Malla de acero inoxidable
D-253/1M \$ 213.477

RECA - 254 \$ 134.778

S - 253 G \$ 64.415

S-253/1G \$ 80.174

Sin tuerca sonda lambda

100 mm RED 1

Ø 1 7/8"

Ø 1 7/8"

FIAT

FIAT PALIO FIRE 1.6 -8V y 16V - 1 Arbol de Levas (1997 - 2001)

FIAT

Malla de acero inoxidable
Con Tuerca sonda lambda
D - 254 M \$ 145.153

ZONDA LAMBDA
Fija CON Zonda Lambda
D - 254 F \$ 96.143

RECA - 254/1 \$ 153.362

D - 254 FSC \$ 76.178

S-253/2G \$ 81.307

S-253/3G \$ 80.174

100 mm RED 1

Ø 2"

150 mm RED 3

FIAT

FIAT PALIO FIRE 1.4 (2007-2010) - UNO 1.4 (2010-2016)

FIAT

S - 253 G \$ 64.415

S-253/5G \$ 71.357

100 mm RED 1

Ø 1 7/8"

OV 2

110 mm

180 mm



FIAT FIAT PALIO WEEKEND TD 1.7 (98-10) - NAFTERO 1.4 8V (06-11) FIAT

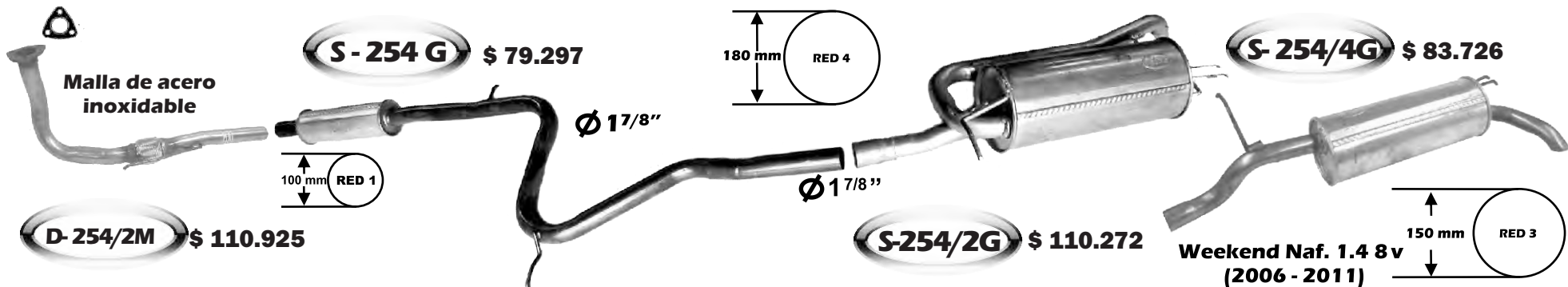

FIAT FIAT PALIO Diesel 1.7 (1997 - 2001) FIAT



FIAT FIAT PALIO NAFTERO 1.8 (2004 - 2010) FIAT

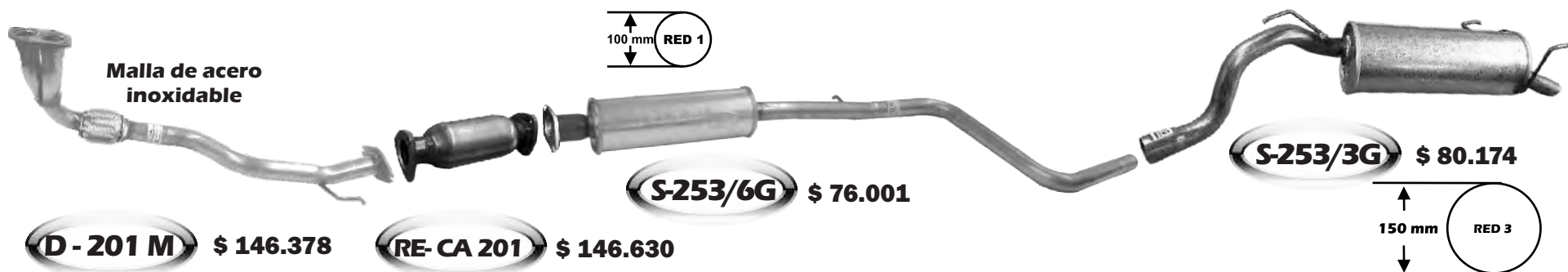



FIAT

FIAT SIENA NAFTERO 1.6 - 8V (1997 - 2001)

FIAT

RECA-254 \$ 134.778

S - 253 G \$ 64.415

D - 254/3F \$ 85.861

SIN Zonda Lambda

CON Zonda Lambda

Ø 17/8"

180 mm RED 4

100 mm RED 1

Ø 17/8"

S - 254/1G \$ 115.841

FIAT

FIAT SIENA NAFTERO 1.8 - 8V (2004 - 2010)

FIAT

Malla de acero inoxidable

RECA-201 \$ 146.630

S-253/6G \$ 76.001

D - 201 M \$ 146.378

100 mm RED 1

180 mm RED 4

Ø 17/8"

S - 254/1G \$ 115.841

FIAT

FIAT SIENA FIRE 1.4 (2010 - 2014)

FIAT

100 mm RED 1

Ø 17/8"

S - 253 G \$ 64.415

150 mm RED 3

S-254/3G \$ 105.354



FIAT

FIAT CRONOS 1.3 MT (2018->)

FIAT

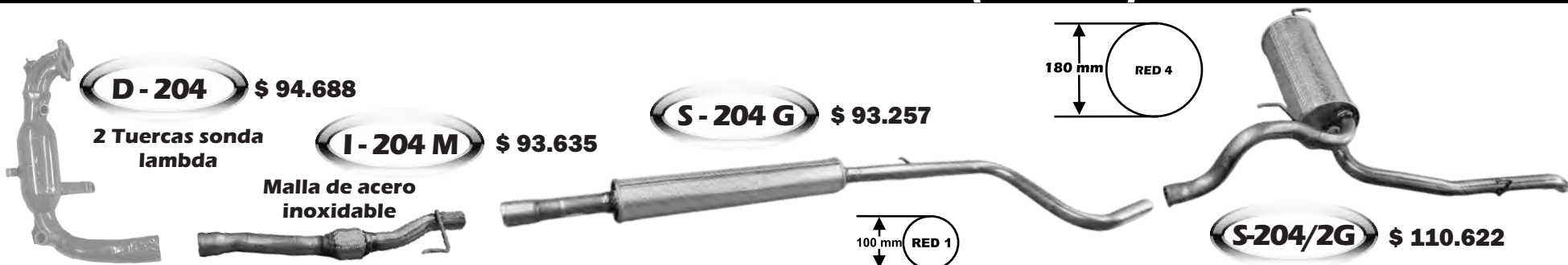

FIAT

FIAT CRONOS 1.3 AT (2018->)

FIAT

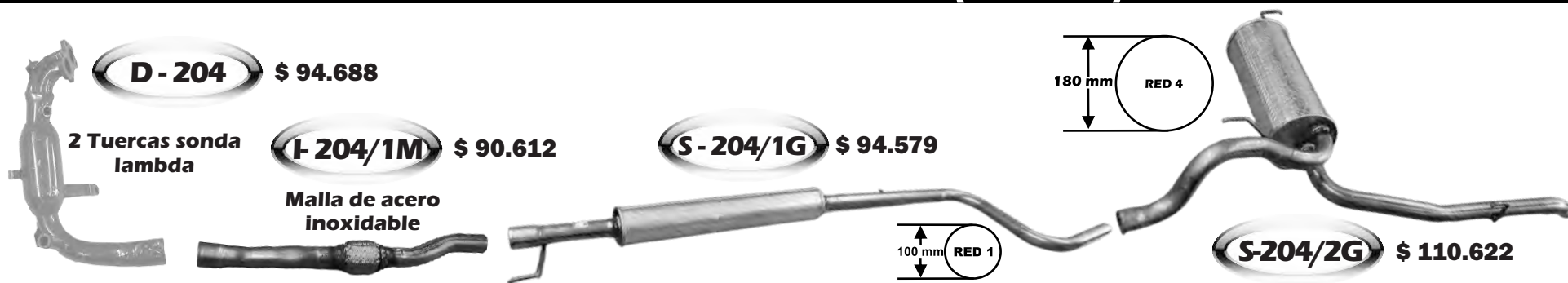

FIAT

FIAT DOBLO 1.4 16V (2013 - 2020) REFORMA A GAS

FIAT

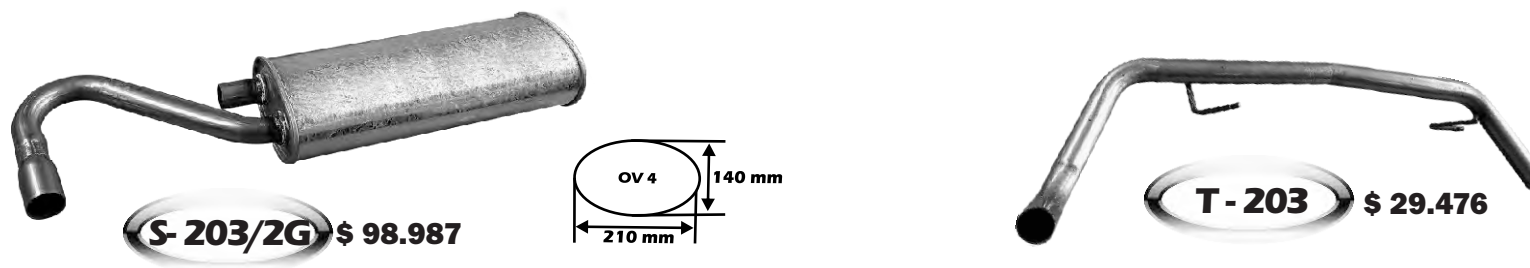



VEHICULO

PÁGINA

FALCON - MONDEO	1/2
COURRIER - ESCORT	3/4
F - 100 - PICK UP	5 A 11
RANGER	12
TRANSIT - FIESTA - TAUNUS	13 A 15
FOCUS - GALAXY	16/17
KA	18/19
SIERRA - ECOSPORT - ORION	20 A 22



MUSSIO ESCAPES





FORD FALCON 170 - 187 (1962 - 1969)



FORD FALCON 188 (1970 - 1982)



FORD FALCON 221 (1970 - 1982)

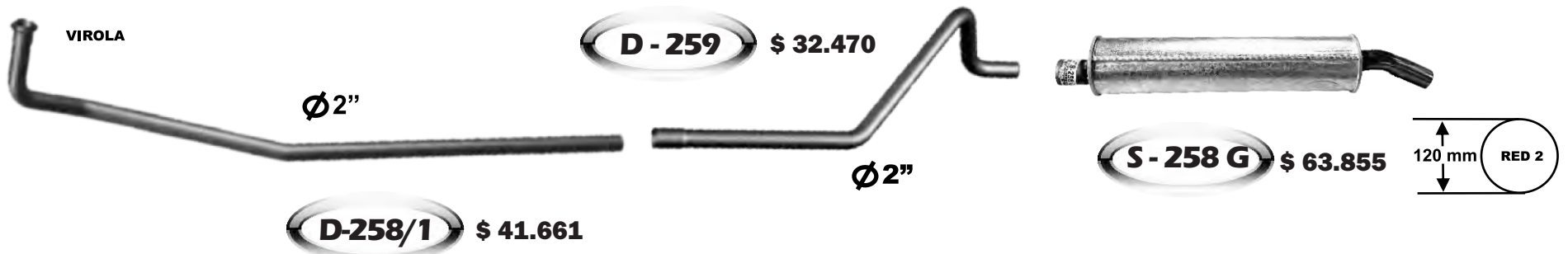



FORD FALCON 3.0 - 3.6 (1982 - 1989)



FORD MONDEO TD - 1.8i (1994 - 1998)



FORD MONDEO 2.0i GHIA (1995 - 2000)

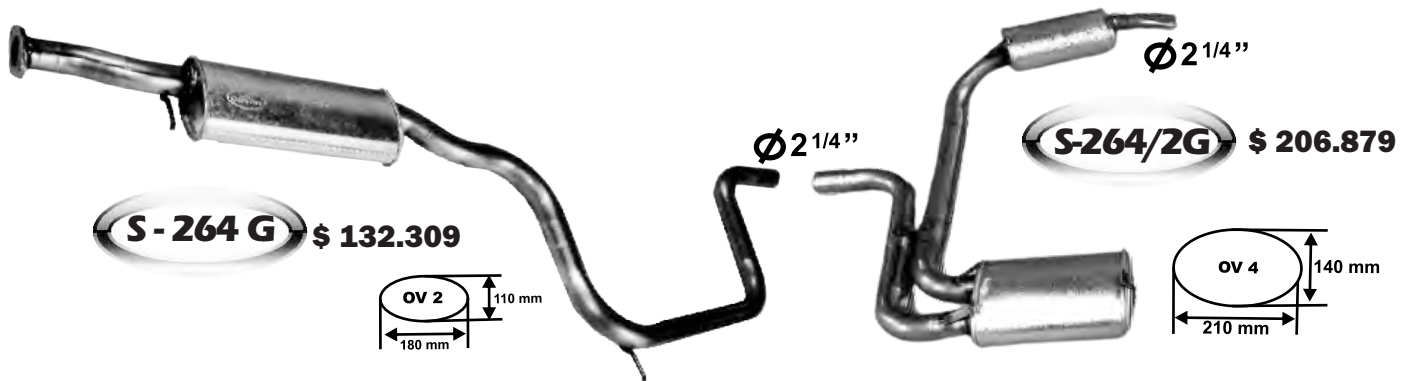



FORD COURIER - VAN (Furgon) - Diesel Endura 1.8 (97-03)

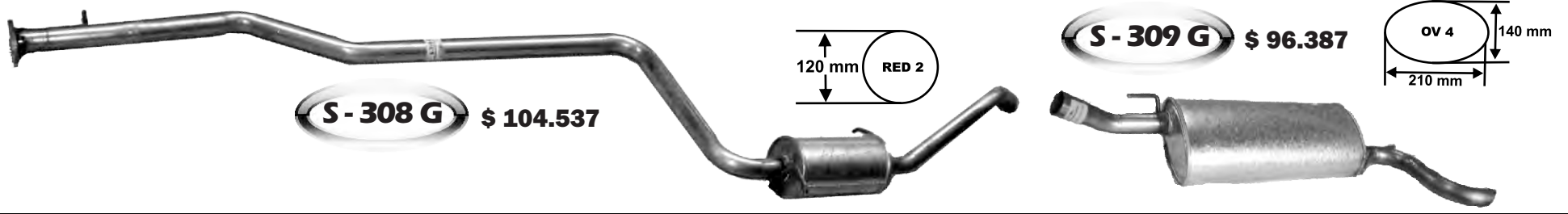

S - 308 G \$ 104.537

S - 309 G \$ 96.387

FORD COURIER PICK UP 1.4 16V Y Diesel (98-00) - 1.6 16v (05-10)



S-308/1G \$ 100.757

S-309/1G \$ 96.387

FORD ESCORT ZETEC 1.8 16V (1997 - 2003)

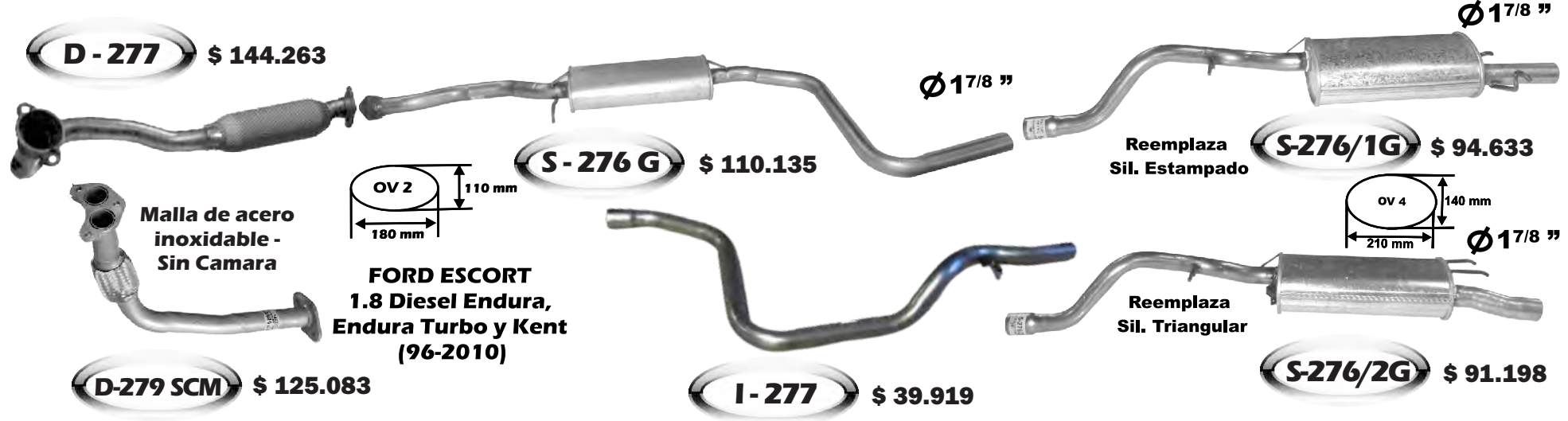

D - 277 \$ 144.263

S - 276 G \$ 110.135

S-276/1G \$ 94.633

Reemplaza Sil. Estampado

Reemplaza Sil. Triangular

S-276/2G \$ 91.198

D-279 SCM \$ 125.083

I - 277 \$ 39.919

Malla de acero inoxidable - Sin Camara

FORD ESCORT 1.8 Diesel Endura, Endura Turbo y Kent (96-2010)



FORD ESCORT 1.6 (1986 - 1990)

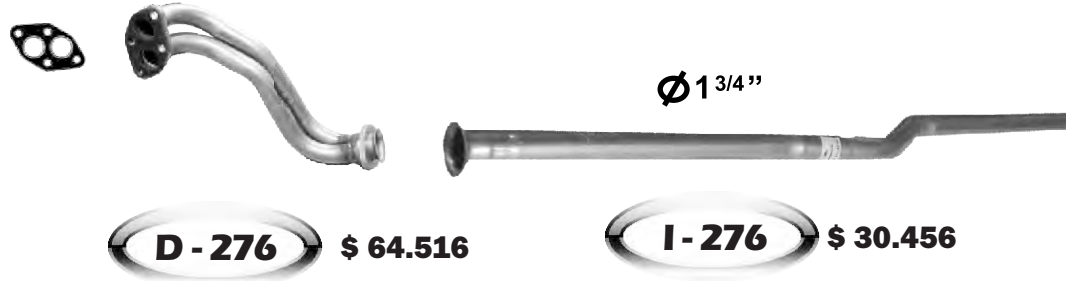

FORD ESCORT (MOTOR AUDI) 1.6 - 1.8 XR3 (1991 - 1992)

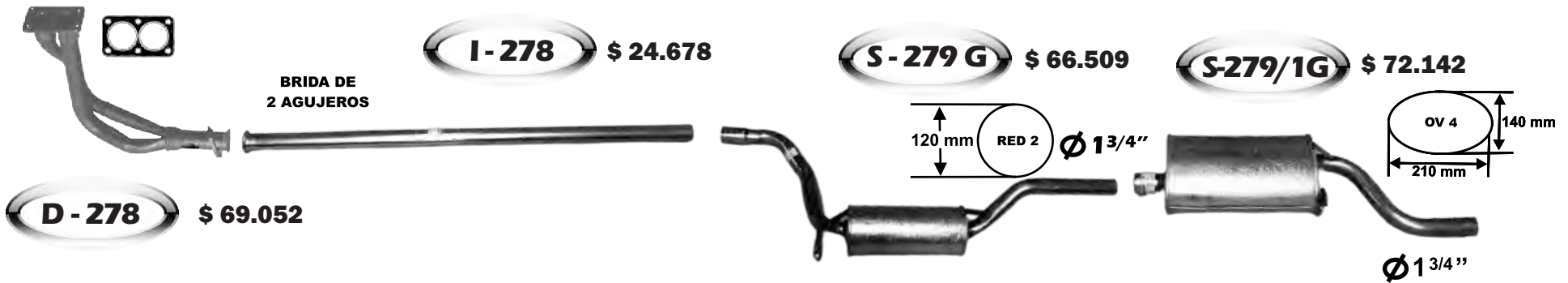

FORD ESCORT (MOTOR AUDI) 1.6 - 1.8XR3 (1993 - 1994)

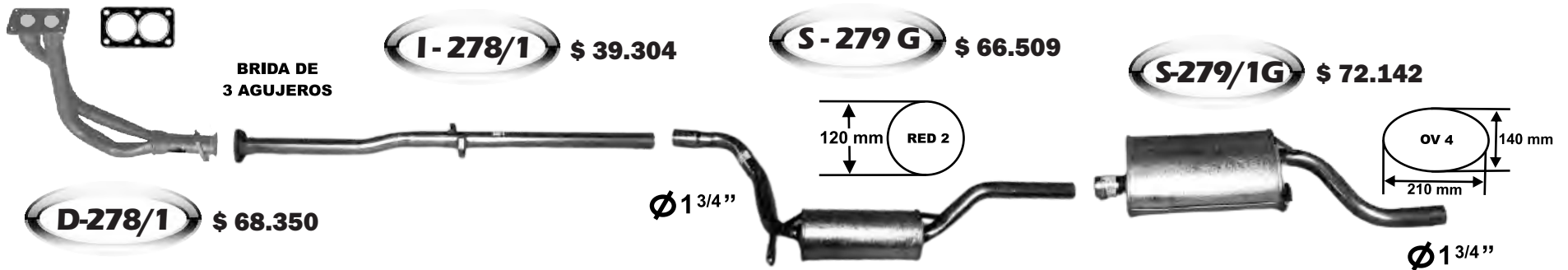



FORD F-100 8 Cilindros (1966 - 1972)

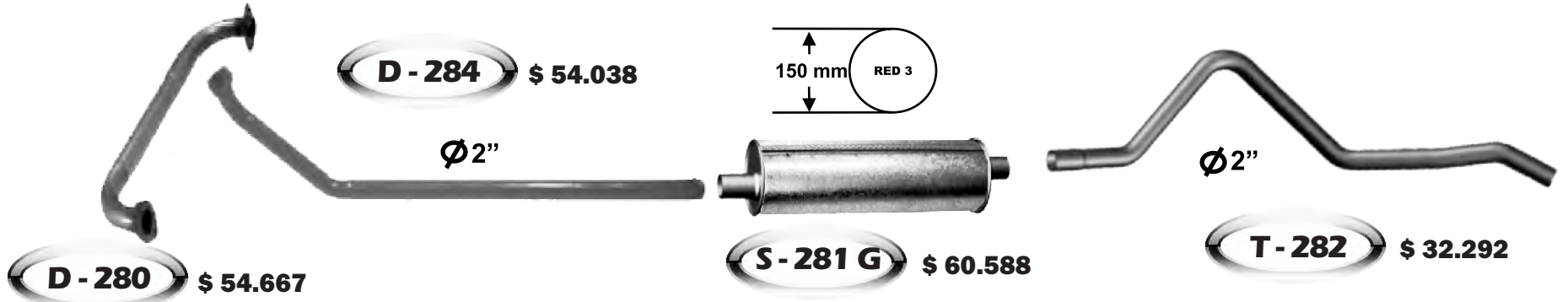

FORD F - 100 6 cilindros (1969 - 1981)

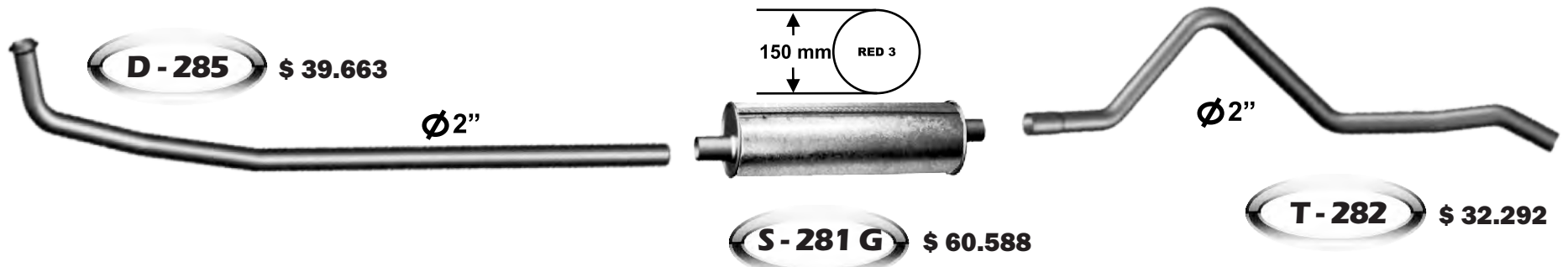

FORD F - 100 Diesel c/Perkins 4/203 (1969 - 1981)

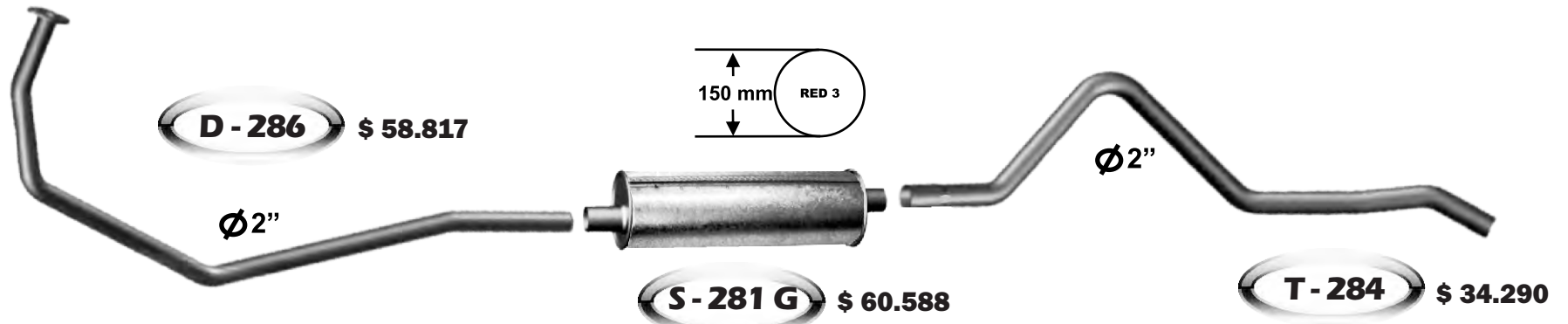



FORD F - 100 8 cil. FASE II (1972 - 1981)

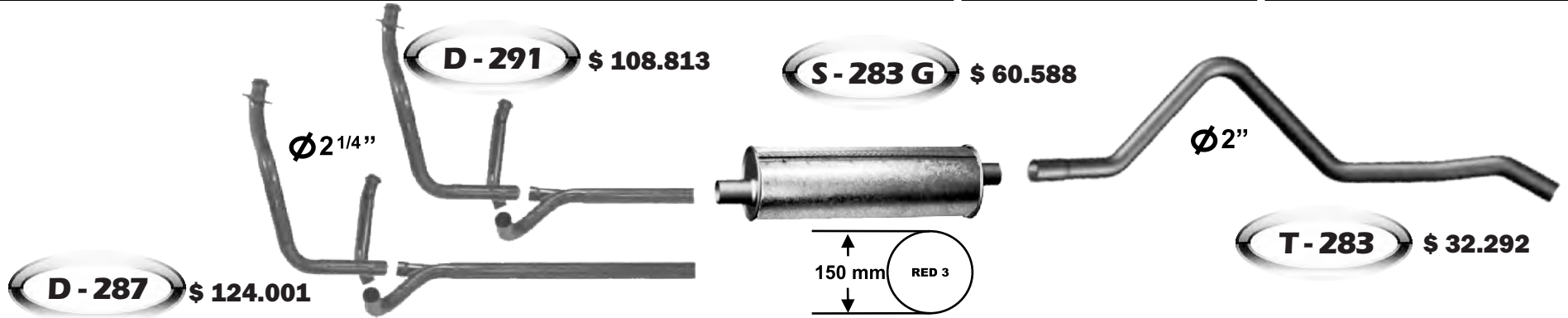

FORD F - 100 Diesel c/Perkins 6/305 (1973 - 1983)

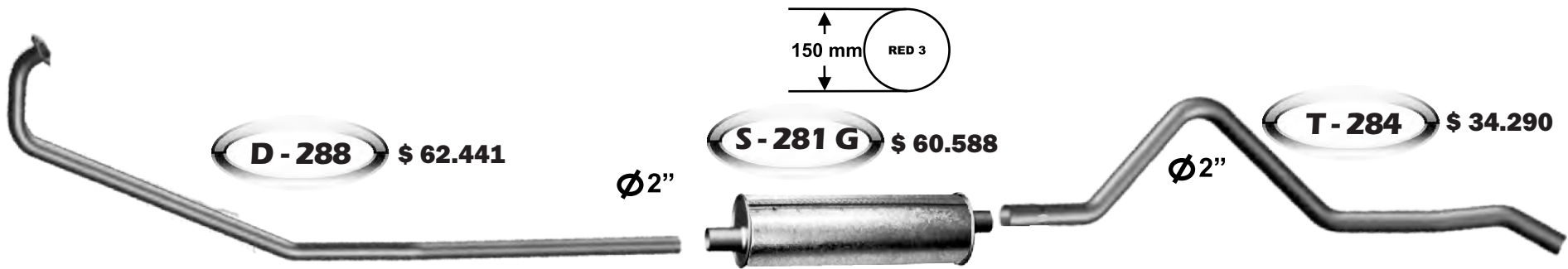

FORD PICK UP 6 cilindros (1982 - 1984)

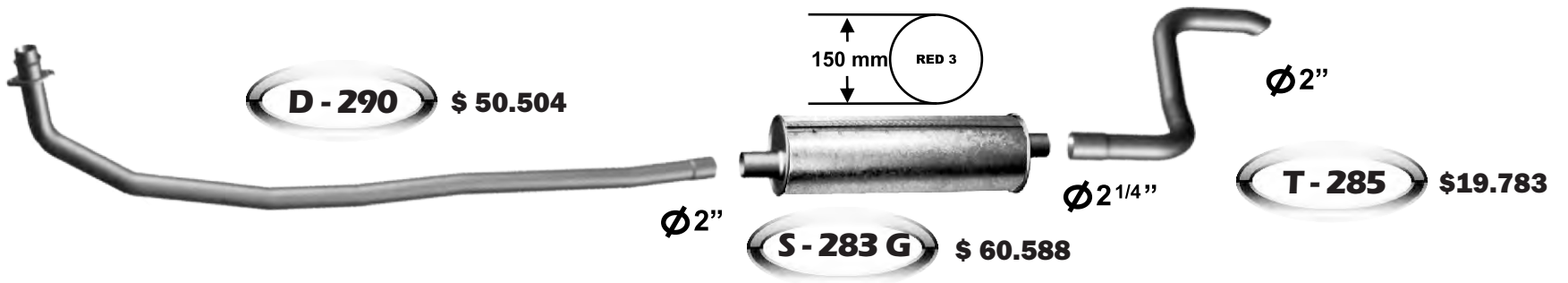



FORD F - 100 Diesel c/Perkins 4/203 (1982 - 1990)



D - 292 \$ 40.635 $\text{Ø}2''$

I - 280 \$ 19.842 $\text{Ø}2''$

S - 283 G \$ 60.588 150 mm RED 3 $\text{Ø}2\frac{1}{4}''$

T - 285 \$ 19.783 $\text{Ø}2''$



FORD F - 100 - Perkins 4 potenciado (1982 - 1990)



D - 293 \$ 40.635 $\text{Ø}2''$

I - 281 \$ 29.133 $\text{Ø}2''$

S - 283 G \$ 60.588 150 mm RED 3 $\text{Ø}2\frac{1}{4}''$

T - 286 \$ 41.461 $\text{Ø}2''$



FORD F - 100 6 cilindros (1986 - 1989)



D - 294 \$ 60.291 $\text{Ø}2''$

S - 283 G \$ 60.588 150 mm RED 3 $\text{Ø}2''$

T - 286 \$ 41.461 $\text{Ø}2''$



FORD F - 100 Diesel c/Perkins potenciado (1982 - 1990)

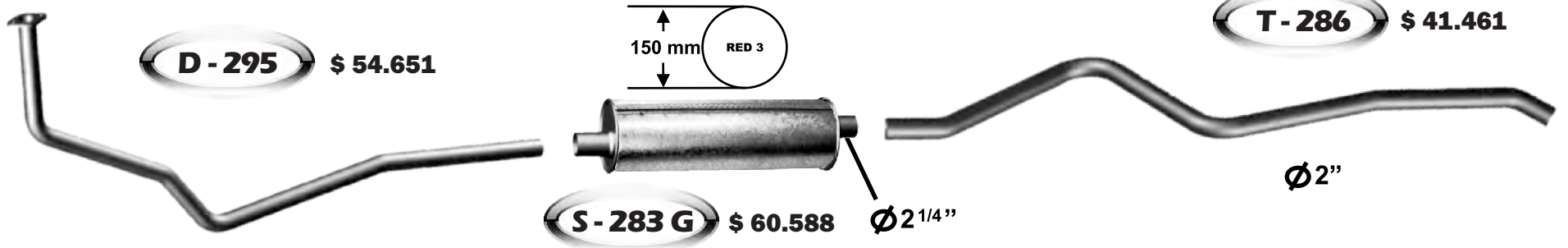

FORD F - 100 6 cilindros Econo E-MAX (1990 - 1996)

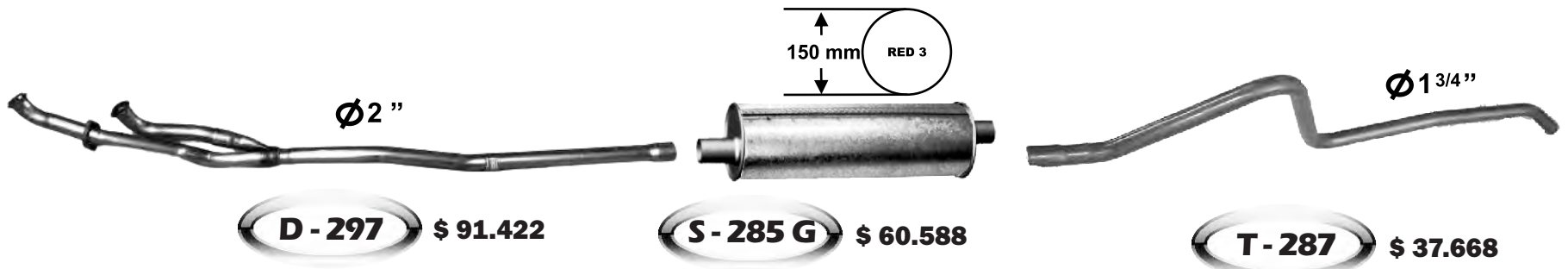

FORD F - 100 6 cilindros MAX Econo (1995 - 1996)





FORD F - 100 6 cilindros Econo E-MAX Reforma a Gas



I-297 \$ 23.463

S-287 GO \$ 125.786

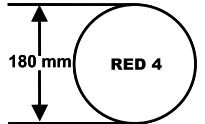

D-297/1 \$ 87.102

Ø2"

Ø 2"



FORD F - 100 DIESEL C/MOTOR DEUTZ



D - 298 \$ 38.273

I - 282 \$ 40.365

S - 286 \$ 56.616

Ø2½"

2" Ø

T - 288 \$ 48.654

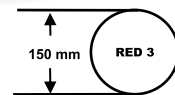

FORD F - 100 DIESEL C/MOTOR DEUTZ REFORMA



D-298/1 \$ 83.485

S - 286 \$ 56.616

Ø2½"

Ø2"

T - 288 \$ 48.654

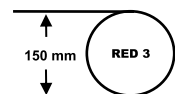

Ø2½"



FORD F - 100 6 cilindros Reforma A Gas (1969 - 1989)

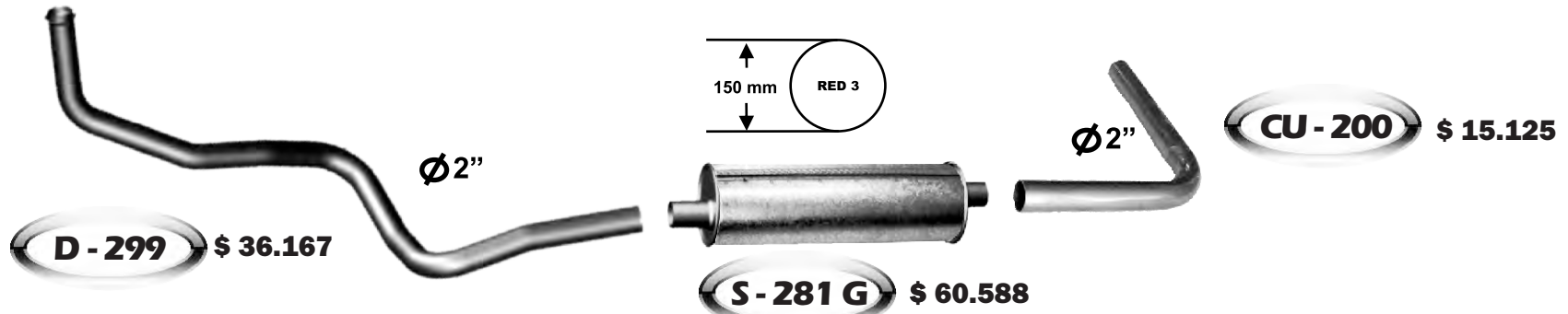

FORD F - 100 DIESEL MWM 4 CIL. (1993 - 1995)



FORD F - 100 MWM 4 CIL. (1996 - 1999) - Turbo Diesel





FORD F- 100 4.9 INYECCION (1996 - 1999)



D - 303 \$ 113.554



S-108 GO \$ 127.899

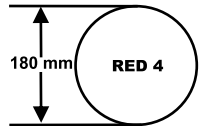

FORD HSD MAXION 2.5 TURBO Diesel (1996 - 1999)



D-303/1 \$ 32.832

Ø2 1/2"

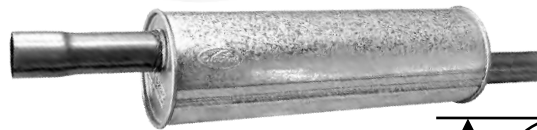

S - 288 G \$ 110.430

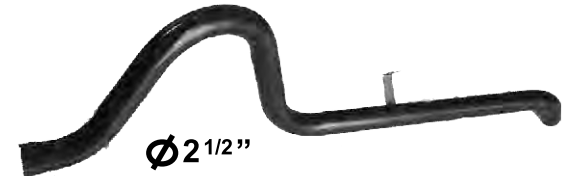
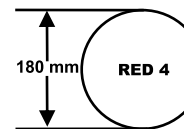

Ø2 1/2"

T - 292 \$ 58.667

I - 284 \$ 30.834



FORD F- 100 DUTTY- CUMMINS TD 3.9 (2000-2012)



D - 316 \$ 54.857

Ø3" (2000-2006)



D - 316/1 \$ 71.777

(2006-2012)



I - 285 \$ 83.182

Ø3"

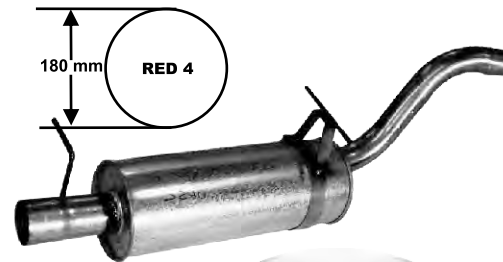

S - 290 G \$ 133.995

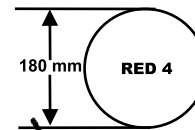

Ø2 1/2"

T - 293 \$ 46.594



FORD RANGER 2.5 TD (98 - 01) - CAB. SIMPLE Y DOBLE

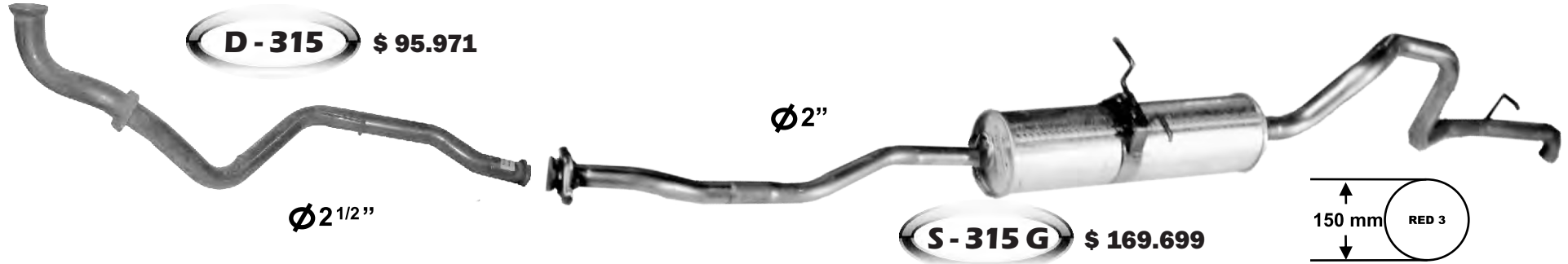

FORD RANGER 2.8 (2002 - 2004)



FORD RANGER 3.0 (2006 - 2012)

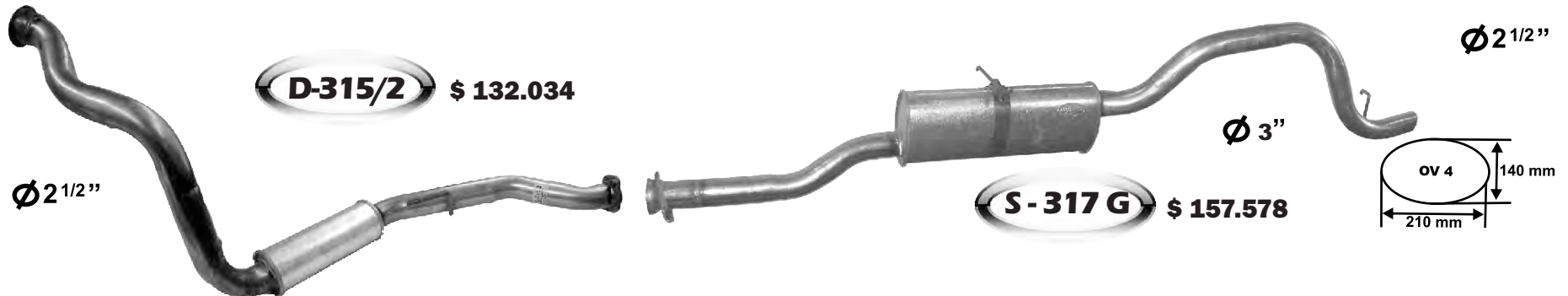



TRANSIT (Caja Corta) (1995-1999)



Tuerca sonda lambda **D-490/1M** \$ 221.877

S-490 G \$ 120.387

MALLA DE ACERO INOXIDABLE

S-490/1G \$ 114.798

OV 2 110 mm 180 mm

OV 2 110 mm 180 mm



TRANSIT DIESEL 2.5 (Caja Larga) (1995-1999)



Tuerca sonda lambda **D-490/1M** \$ 221.877

S-490/2G \$ 104.948

S-490/3G \$ 81.269

Malla de acero inoxidable

T-490 \$ 59.747

Ø 2 1/4"

180 mm RED 4



FORD FIESTA KINECTIC 1.6 NAFTERO (2010 ->)



S-301 G \$ 101.819

COLA DOBLE (2010-2013)

S-301/1G \$ 102.819

COLA SIMPLE (2013-2020)

S-301/2G \$ 97.203

100 mm RED 1

80 mm RED 4



FORD TAUNUS GHIA L 2300

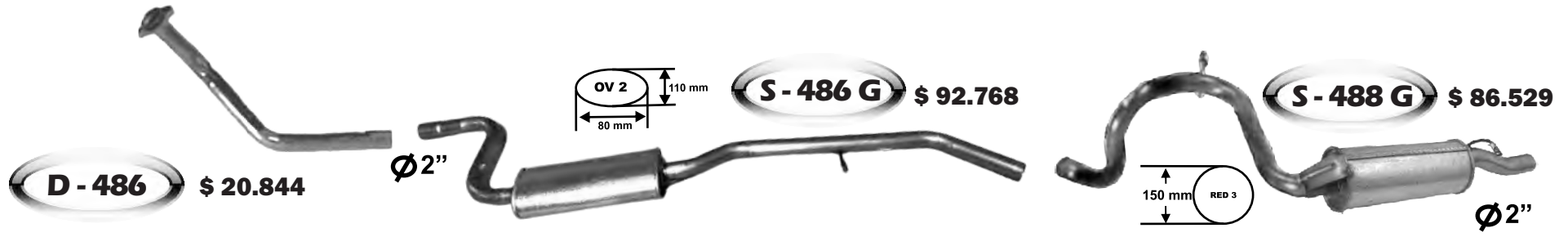

FORD FIESTA 1.3 - 1.4 (1995 - 1996)

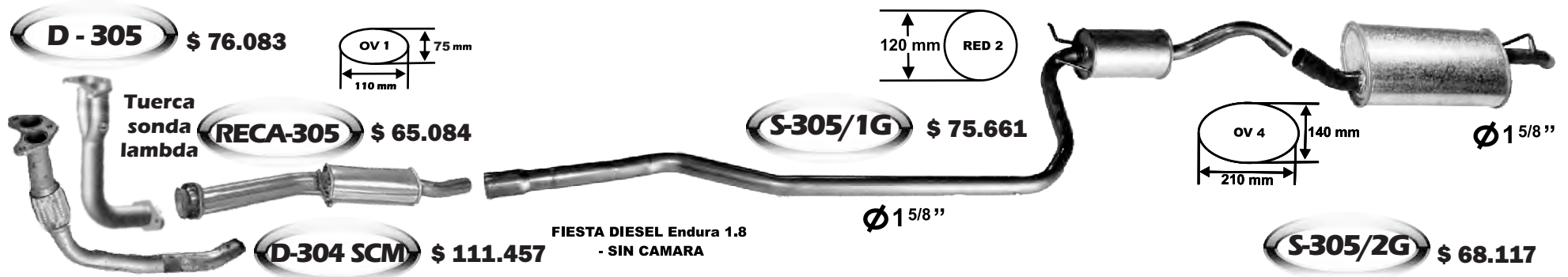

FORD FIESTA NAFTERO 1.3i - 1.4i - 1.8 Diesel (97-02)

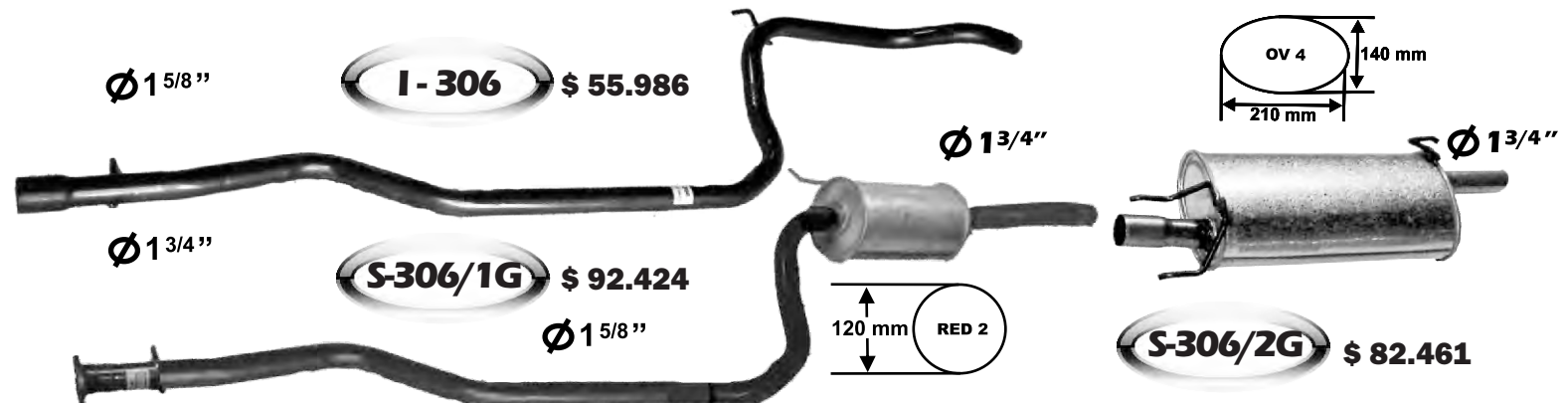



FORD FIESTA NAFTERO 1.6 - 1.4 Diesel (2002-2011)



Tuerca sonda lambda **D - 306** \$ 69.284 $\varnothing 1\frac{3}{4}$ "

S - 302 G \$ 75.241

S-303/2G \$ 91.846

OV 2 110 mm
180 mm

180 mm RED 4

$\varnothing 1\frac{3}{4}$ "



FORD FIESTA MAX 1.6 NAFTERO (2005 - 2010) - C/BAUL



Tuerca sonda lambda **D - 306** \$ 69.284 $\varnothing 1\frac{3}{4}$ "

S-302/1G \$ 75.241

S-303/1G \$ 91.846

OV 2 110 mm
180 mm

$\varnothing 1\frac{3}{4}$ "

180 mm RED 4



FORD FIESTA ONE 1.6 SIN BAUL (2010 - 2014)



I - 302 \$ 24.824

S-302/1G \$ 75.241

S-303/1G \$ 91.846

OV 2 110 mm
180 mm

$\varnothing 1\frac{3}{4}$ "

180 mm RED 4



FORD FOCUS 1.8 I (Sin Baul) (2000 -2005)

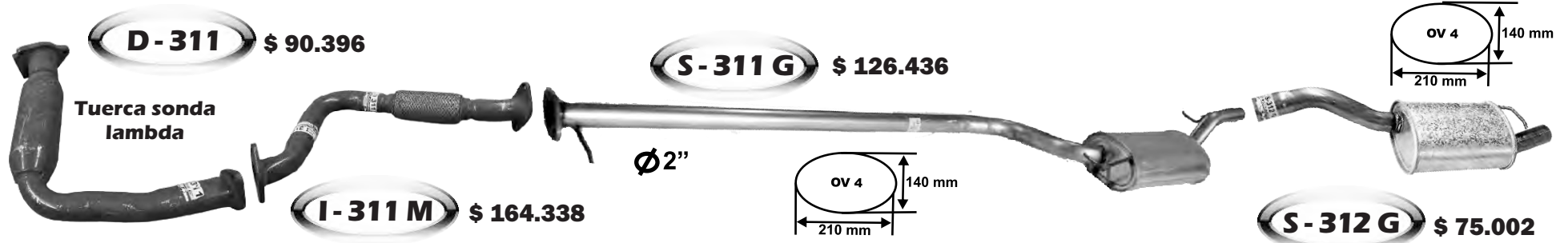

FORD FOCUS 2.0 I (Con Baul) (2000 - 2008)

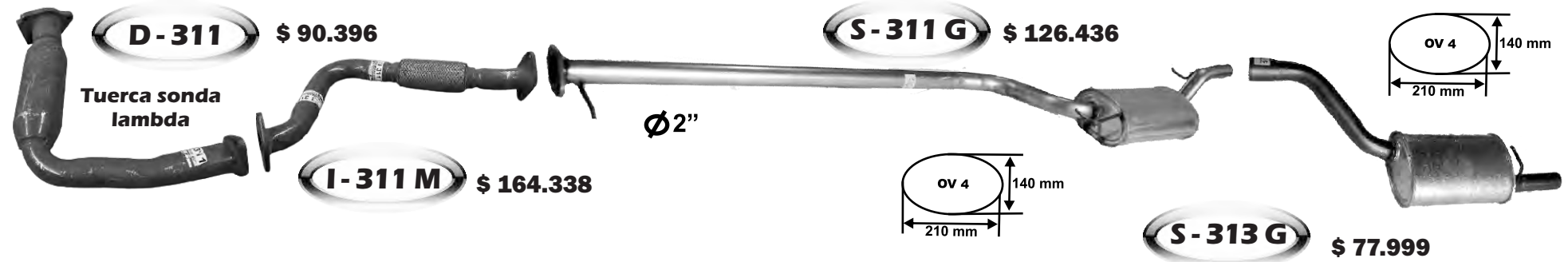

FORD FOCUS 1.6 I - 2.0 (2004 - 2008) (Sin Baul)

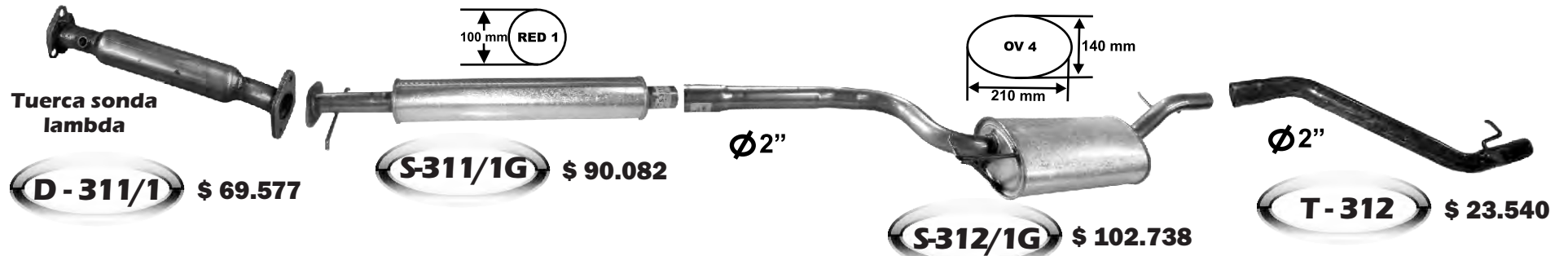



FORD FOCUS 1.6 I - 2.0 (Con Baul) (2004 - 2008)



Tuerca sonda lambda

D - 311/1 \$ 69.577

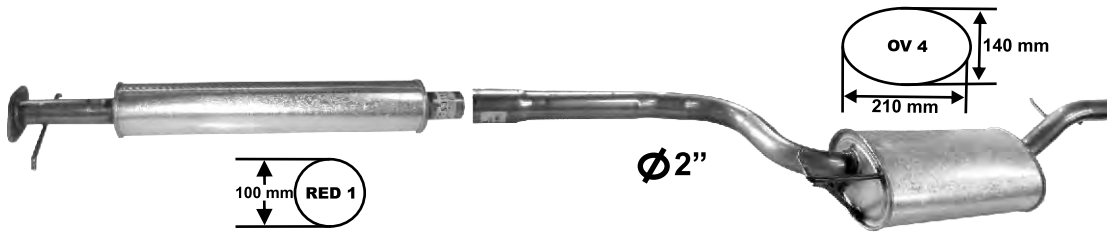

S-311/1G \$ 90.082

S-312/1G \$ 102.738



T - 313 \$ 27.536



FORD FOCUS III 1.6 - 2.0 Naftero (2013 - 2020)



Malla de acero inoxidable

Tuerca sonda lambda

D - 314 M \$ 399.000

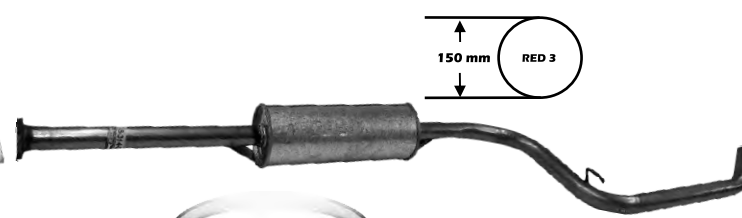

S - 314 G \$ 124.635



SIN BAUL EN ACERO INOX.

S-314/10 \$ 126.000



CON BAUL EN ACERO INOX.

S-314/20 \$ 126.000



FORD GALAXY (1992 - 1995)



D - 516 \$ 89.518



Tuerca sonda lambda

2.0 INYECCION

D - 489 \$ 96.544

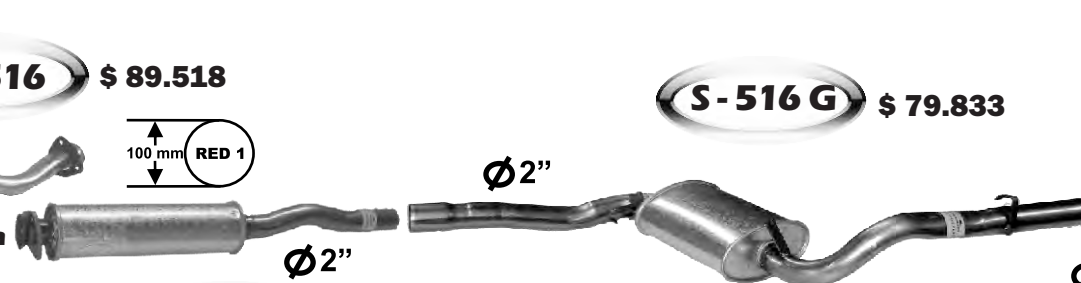

S - 523 G \$ 72.468

S - 516 G \$ 79.833

S-489/3G \$ 88.826



Ø2"

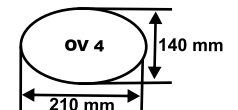
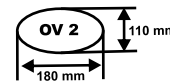



FORD KA 1.0 Naftero (1997 - 2008)



D - 324 \$ 59.753

S - 324 G \$ 67.277

S-324/1G \$ 76.704

Tuerca sonda lambda

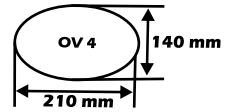
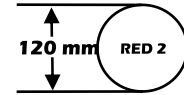

FORD KA 1.3 i Naftero (1997 - 1999)



I - 320/1 \$ 36.583

I - 320 M \$ 123.070

S - 320 G \$ 84.010

Malla de acero inoxidable

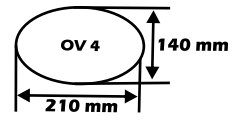
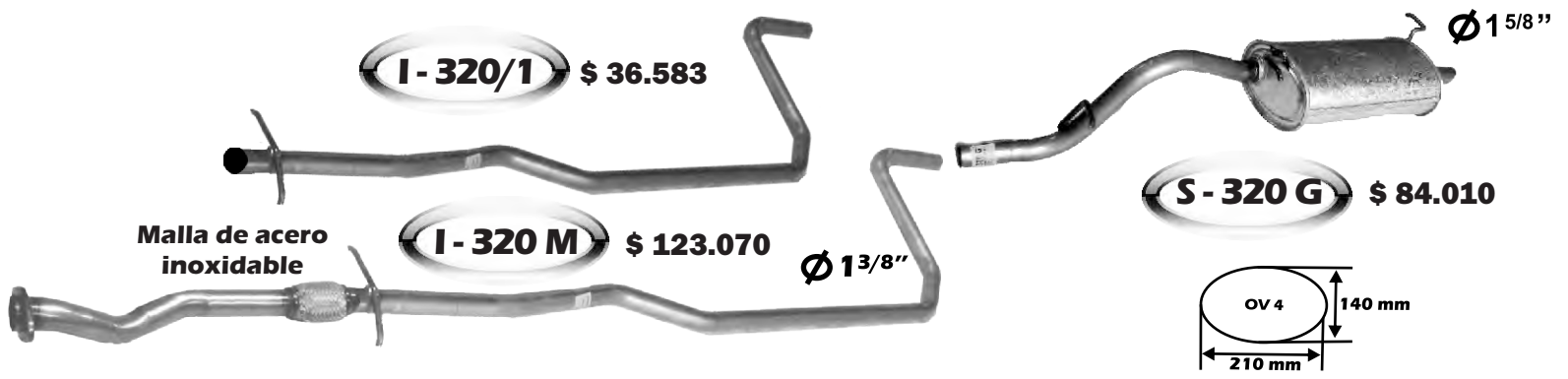

FORD KA 1.5 (2016 - 2021)



S - 307 G \$ 99.321

S-307/1G \$ 98.563

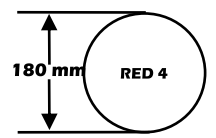
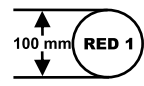



FORD KA 1.6 Naftero ZETEC (2001 - 2008)

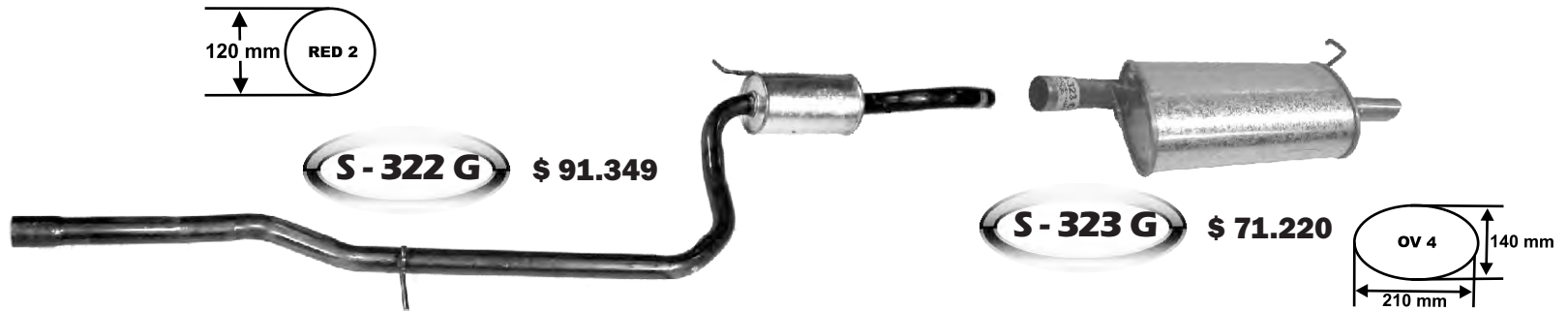

FORD KA 1.6 Naftero ZETEC (2008 - 2010)

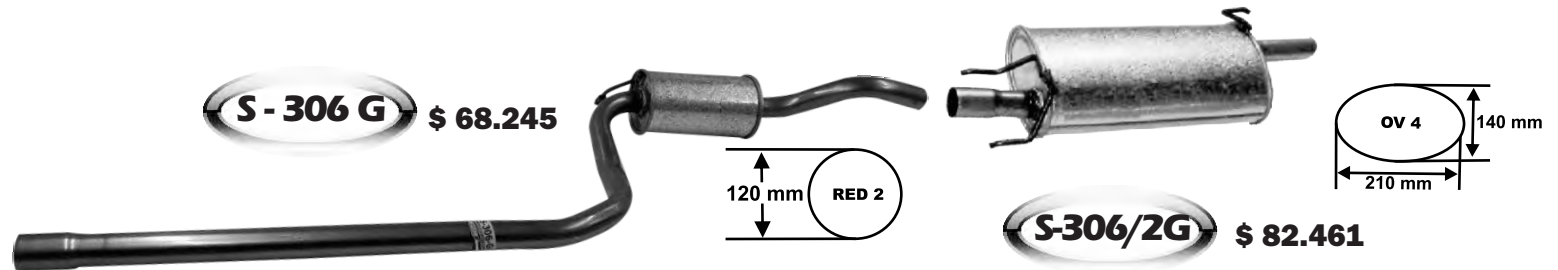

FORD KA 1.6 Naftero (2010 - 2014)





FORD SIERRA GHIA 2.3 (1984 - 1993)



X R4 $\varnothing 2''$ **D - 477** \$ 54.509

D - 475 \$ 76.025

1.6 (87-92)

D - 476 \$ 61.587

2.3 (84-93)

S - 477 G \$ 73.163

S475/1G \$ 74.381

OV 2 110 mm 180 mm

$\varnothing 1 5/8''$

$\varnothing 1 3/4''$

150 mm RED 3



FORD ECOSPORT 1.6 i (2003 - 2007)



Intermedia para Reforma a Gas 1.6

I - 303 \$ 25.380

D - 306 \$ 69.284

Tuerca sonda lambda $\varnothing 1 3/4''$

S - 302 G \$ 75.241

S-303/2G \$ 91.846

OV 2 110 mm 180 mm

$\varnothing 1''$

180 mm RED 4



FORD ECOSPORT 1.6 Naftero (2008 - 2012)



I - 302 \$ 24.824

S-302/1G \$ 75.241

S-303/1G \$ 91.846

OV 2 110 mm 180 mm

180 mm RED 4



FORD ECOSPORT 2.0 Naftero (4X2) (2003 - 2012)

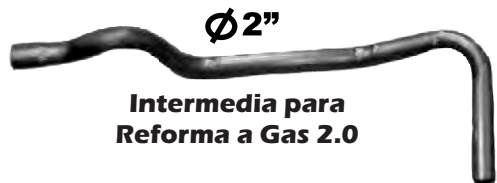

Intermedia para Reforma a Gas 2.0

I - 304 \$ 31.077

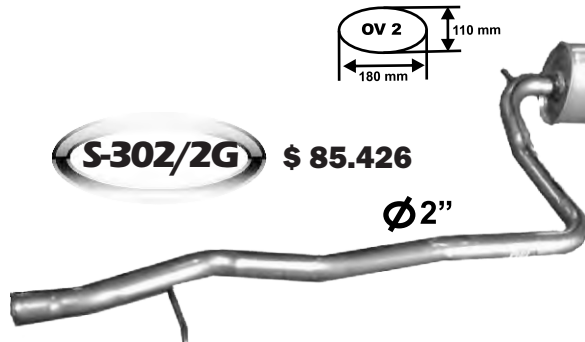

S-302/2G \$ 85.426

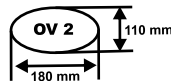

Ø2"



S - 304 G \$ 105.616

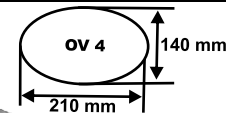

FORD ECOSPORT 2.0 Naftero (4X4)



S-302/3G \$ 88.710

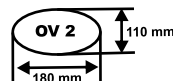

S-304/1G \$ 107.614

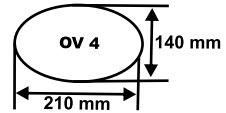

FORD ECOSPORT KINECTIC 1.6 (2012 - 2017)



S-302/4G \$ 112.372

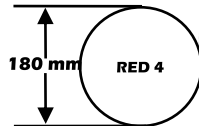
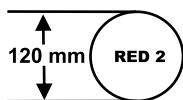

S-303/4G \$ 97.036

S-303/5G \$ 83.283

REFORMA A GAS

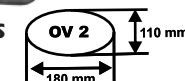



FORD ECOSPORT KINECTIC 2.0 (2013 - 2017)



S-302/6G \$ 128.520

S-303/6G \$ 126.243

S-303/7G \$ 74.588

REFORMA A GAS PARA TUBOS GRANDES

OV 2 110 mm 180 mm

OV 4 140 mm 210 mm

OV 2 110 mm 180 mm

FORD ECOSPORT KINECTIC 1.5 3cil. (2017 - 2022)



D-302/8M \$437.119

S-302/8G \$ 84.751

S-303/8G \$ 98.399

Tuerca sonda lambda

Tuerca sonda lambda

Malla de acero inoxidable

120 mm RED 2

180 mm RED 4

FORD ORION 1.6 - 1.8 - 2.0 (1994 - 1996)



D-550 F \$ 84.890

RECA-556 \$ 68.553

S-550/1G \$ 104.636

S-310/3G \$ 96.006

FIJA SIN MOVIMIENTO

Malla de acero inoxidable

Ø2"

OV 2 110 mm 180 mm

OV 4 140 mm 210 mm



PEUGEOT

VEHICULO PÁGINA

106 - 205 - 406	1
206-206 RURAL	2/3
207	4
208	5
306	6/7
404 - 405	8
504 - 505 - 504 PICK UP	9/10
PARTNER	11/12
307 - 408	13/14





PEUGEOT 106 1.4 i (1998-2002)

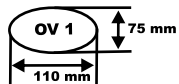

S - 347 G \$ 59.599

Ø1 1/2"

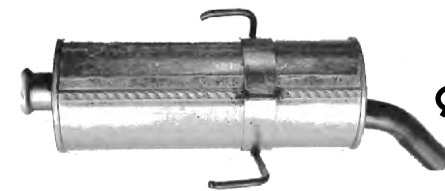

Ø1 3/4"

S - 348 G \$ 79.060

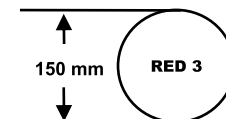

PEUGEOT 205 XS (1994-1999)

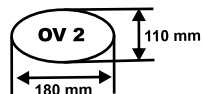

S-2430 G \$ 75.418

Ø1 3/4"



Ø1 3/4"

S-2430/1G \$ 82.197

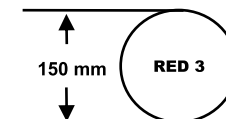

PEUGEOT 406 2.0 Diesel (1997 - 2001)



D-394/2G \$ 94.781

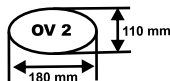

I - 394 \$ 60.827



Ø2 1/4"

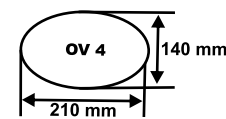
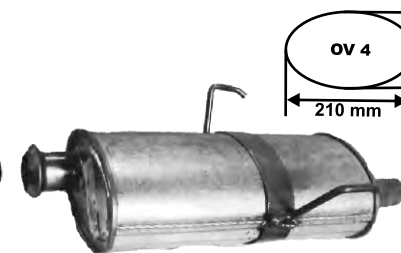

S - 395 G \$ 102.360



PEUGEOT 206 1.4 (1999 - 2003) - 1.6i 16V (2004 - 2008)



I - 350 \$ 29.016

Salida de motor
c/reemplaza
Catalizador

D - 350 \$ 90.025

Reemplaza
catalizador

D-350 SC \$ 50.800

S - 351 G \$ 80.918

Ø 1 3/4"

S - 353 G \$ 88.030

I - 351 \$ 42.246

OV 2
110 mm
180 mm



PEUGEOT 206 1.6 I NACIONAL (1999 - 2003)



D - 353 \$ 65.448

Tuerca
sonda
lambda

RECA - 352 \$ 46.359

S - 352 G \$ 86.696

Ø 1 3/4"

S - 353 G \$ 88.030

I - 352 \$ 31.223

OV 2
110 mm
180 mm

150 mm
RED 3



PEUGEOT 206 1.6 16V INYECCION (2004->)



Salida de motor con reemplaza Catalizador

D - 350 \$ 90.025 **I - 350** \$ 29.016 **S - 351 G** \$ 80.918 **S-353/2G** \$ 113.815

COLA CROMADA



PEUGEOT 206 DIESEL 1.9 (1999-2006)



D-353/1 \$ 69.698 **I - 353** \$ 36.134 **S - 353/1G** \$ 92.755



PEUGEOT 206 1.6 SW (2005 - 2009)



Salida con Reemplaza Catalizador

D - 350 \$ 90.025 **I - 350** \$ 29.016 **S - 354 G** \$ 97.172 **S - 354/1G** \$ 99.900



PEUGEOT 207 1.6 16V (2008-2013)



Salida con Reemplaza Catalizador

Malla de acero inoxidable

Tuerca sonda lambda

OV 2 110 mm 180 mm

I-356 \$ 36.134

SiN Baul

CON Baul

Ø 1 3/4"

RED 3 150 mm

D-357 M \$ 199.003

S-356 G \$ 68.287

I-356/2 \$ 39.730

S-353 G \$ 88.030



PEUGEOT 207 Diesel HdI



I-356/1 \$ 46.124

RED 3 150 mm

S-356/2G \$ 100.234



PEUGEOT 207 1.4 NAFTERO (2009 - 2015)



Ø 1 3/4"

SIN BAUL

CON BAUL

Ø 1 3/4"

I-357 \$ 51.119

I-357/1 \$ 53.939



PEUGEOT 208 1.6 16V (2013 - 2019)

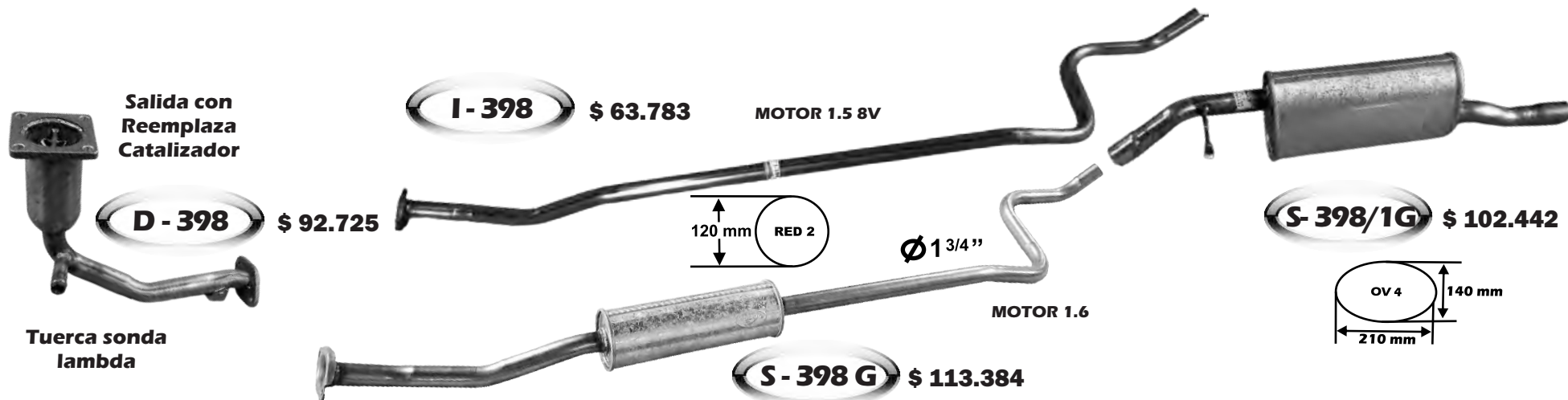

PEUGEOT 208 1.6 16V (2019->)





PEUGEOT 306 1.8i (1996 - 1998) - Sin Baul



D - 359 \$ 48.105



S - 358/1G \$ 82.375

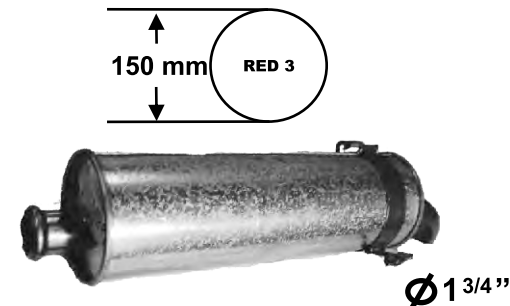

S - 359 G \$ 96.343

PEUGEOT 306 1.8i (1996 - 1998) - Con Baul



D - 359 \$ 48.105



S - 358 G \$ 82.915

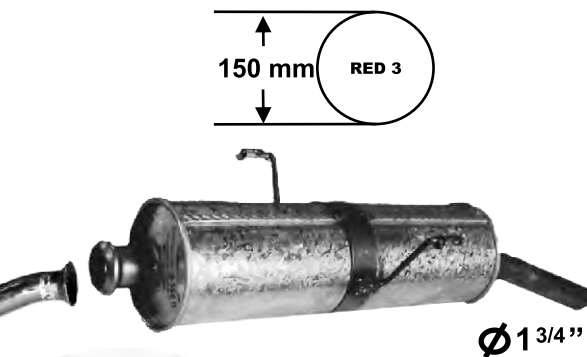

S - 360 G \$ 96.343



PEUGEOT 306 1.9 Diesel - Con Baul (1995 - 2001)



Ø 1 3/4"

D - 358 \$ 48.105



Ø 1 3/4"

S - 360 G \$ 96.343

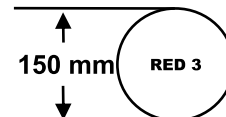

PEUGEOT 306 1.8 MPI 16V - Sin Baul (1999 - 2003)

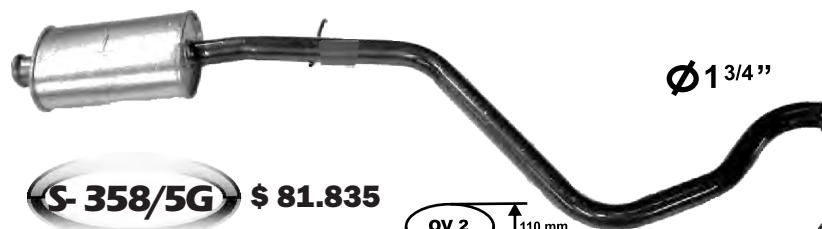

Ø 1 3/4"

S - 358/5G \$ 81.835

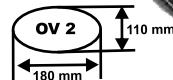

Ø 2"

S - 359/1G \$ 99.277

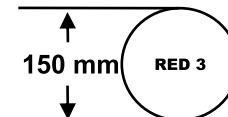

PEUGEOT 306 1.8 MPI 16V - Con Baul (1999 - 2003)



Ø 1 3/4"

S - 358/4G \$ 100.035

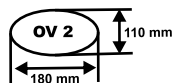

Ø 2"

S - 360/1G \$ 101.956

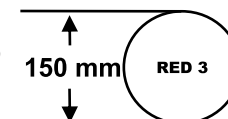



PEUGEOT 404 Diesel (1971 - 1978)



PEUGEOT 405 SR (1993 - 1999)

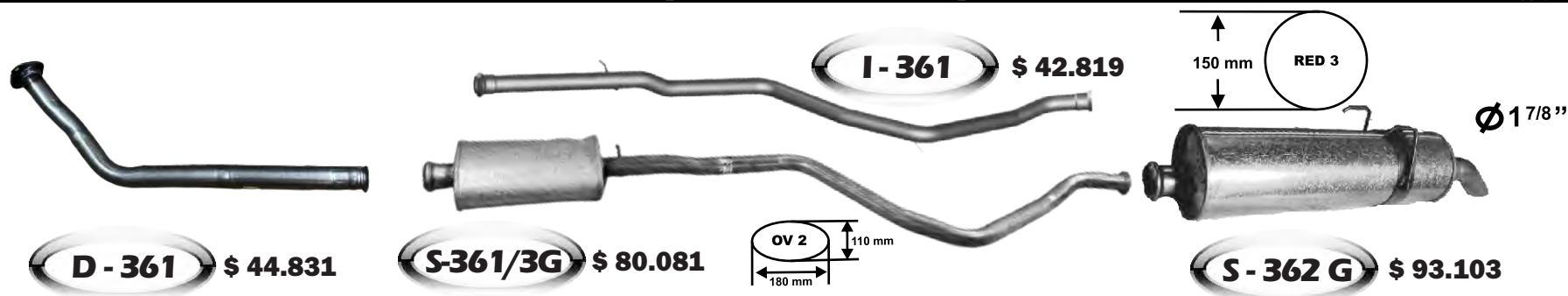

PEUGEOT 405 SRI - SRD - SRDT (1993 - 1997)

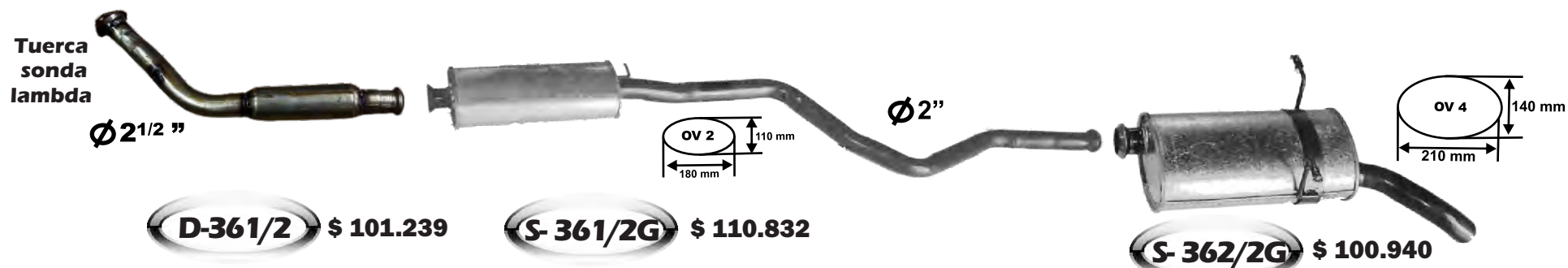



PEUGEOT 504 (1969 - 1982)



PEUGEOT 504 (1969 - 1982)

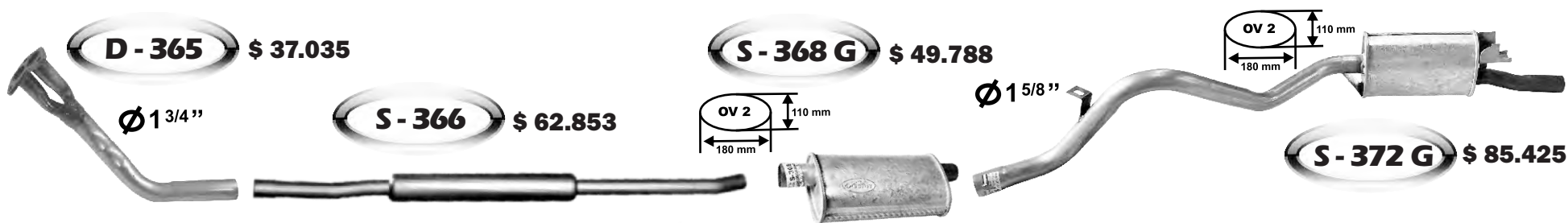

PEUGEOT 504 (1983 - 1990) - 505 (1983 - 1992)

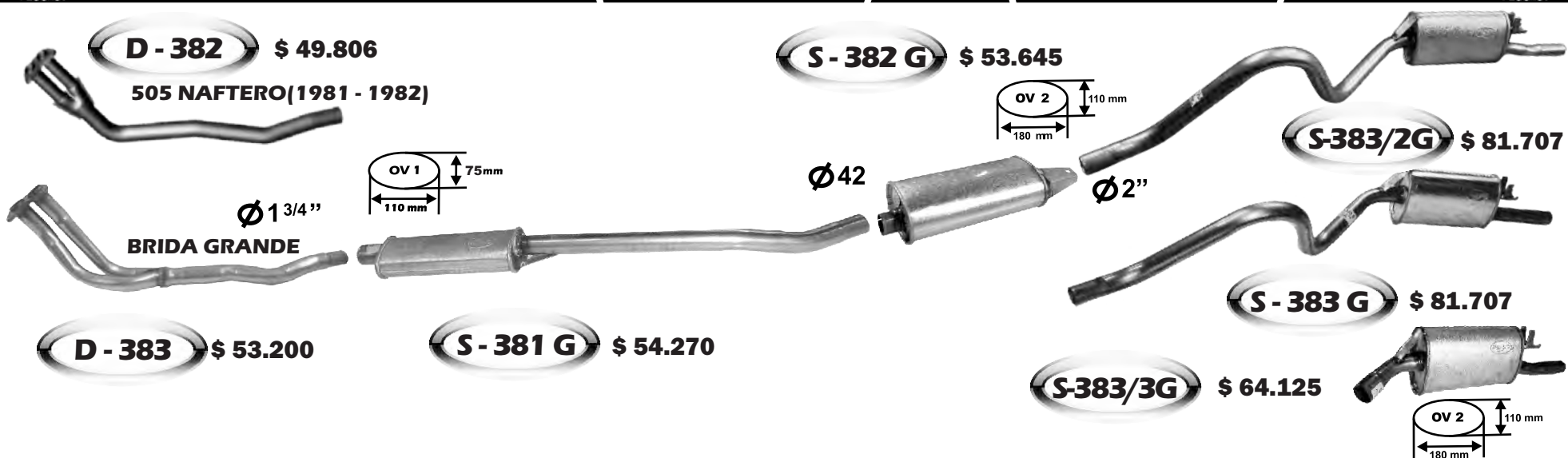



PEUGEOT 504 Diesel Ligero (1993 - 1998)



PEUGEOT PICK UP 504 NAFTERO (1981 - 1999)

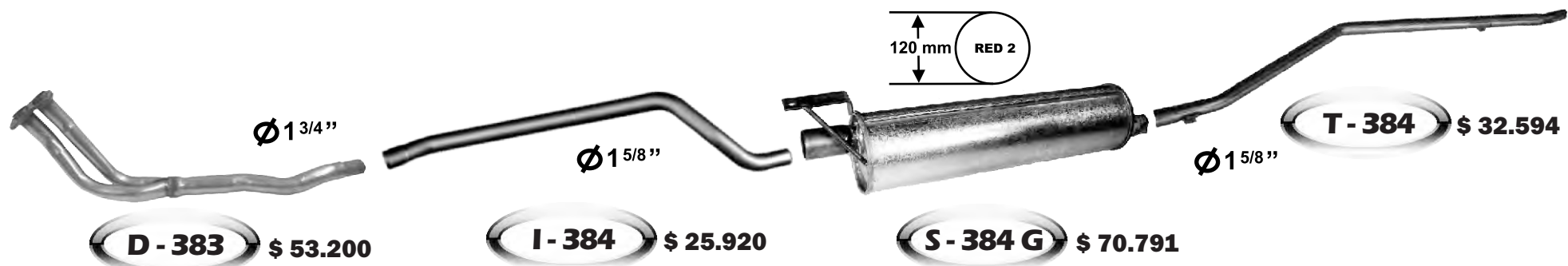

PEUGEOT PICK UP 504 Diesel Ligero (1993 - 1999)

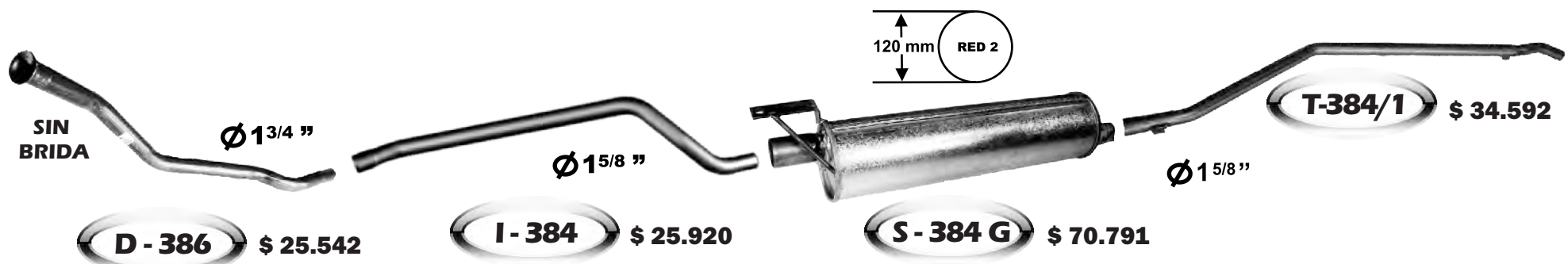



PEUGEOT PARTNER (BERLINGO) 1.8 NAFTERO



D - 393 \$ 99.351

I - 393 \$ 33.012

S - 392 G \$ 74.489

S - 393 G \$ 93.805

OV 2: 180 mm x 110 mm

OV 4: 210 mm x 140 mm



PEUGEOT PARTNER (BERLINGO) 1.4 NAFTERO (1998 - 2009)



Reemplaza catalizador

Tuerca sonda lambda

D - 350 SC \$ 50.800

D - 393/1 \$ 109.077

S-392/1G \$ 65.363

S - 393 G \$ 93.805

OV 1: 110 mm x 75 mm

OV 4: 210 mm x 140 mm

Ø 1 3/4"



PEUGEOT PARTNER (BERLINGO) - Diesel 1.9 (1998 - 2010)



D - 392 \$ 78.203

I - 392 \$ 40.766

S - 393 G \$ 93.805

Ø 1 3/4"

OV 4: 210 mm x 140 mm



PEUGEOT PARTNER 1.6 HDI (2010 ->)

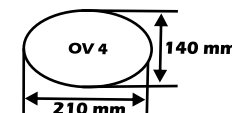

I-393/1 \$ 65.363

S-393/3G \$ 106.157



PEUGEOT PARTNER (BERLINGO) 1.4 NAFTERO (98 - 04)

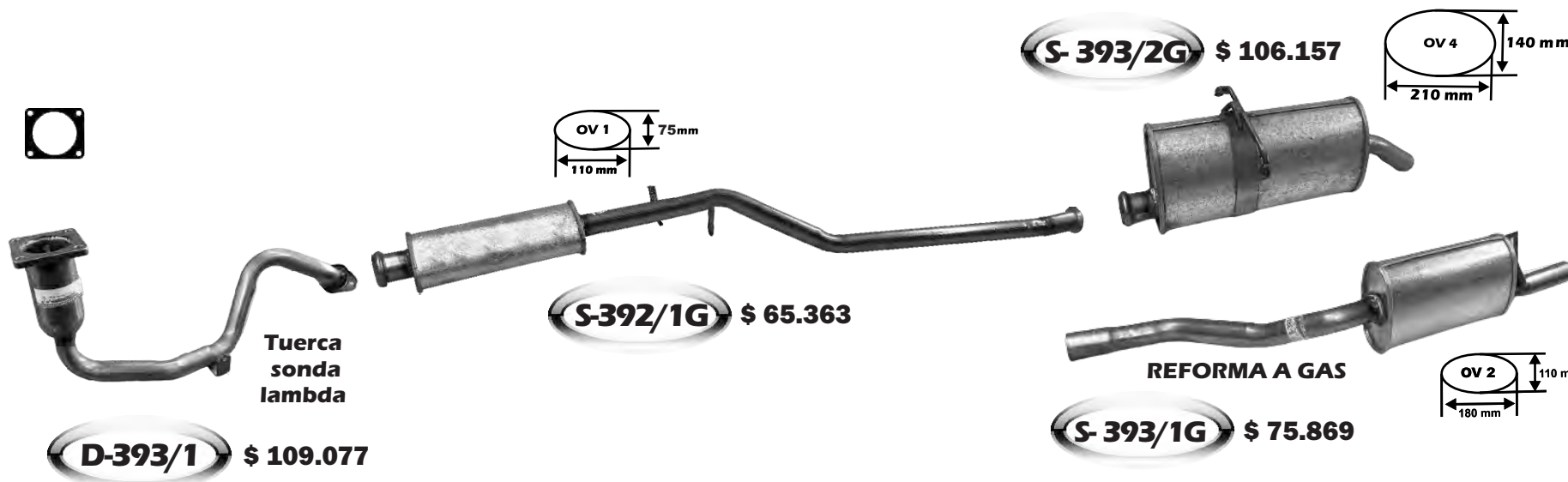

S-393/2G \$ 106.157

S-392/1G \$ 65.363

S-393/1G \$ 75.869

Tuerca
sonda
lambda

D-393/1 \$ 109.077

REFORMA A GAS



PEUGEOT 307 1.6i 110cv (2001 - 2012)



Reemplaza catalizador

D-350 SC \$ 50.800

S-396/1G \$ 94.645

S-397/2G \$ 113.900

D-396 \$ 100.717

S-397/3G \$ 115.898

Tuerca sonda lambda
 P.307 1.6 16V (2010-12)
 P.308 1.6 16V (2012->)

D-396/1 \$ 108.073

S-40 G \$ 70.709

I-396 \$ 42.794

180 mm RED 4

100 mm RED 1

100 mm RED 1

SIN BAÚL

CON BAÚL



PEUGEOT 307 2.0 16V (2001 - 2006)



S-397 G \$ 114.899

S-397/1G \$ 118.396

S-396 G \$ 112.644

100 mm RED 1

Ø2"

180 mm RED 4

SIN BAÚL

CON BAÚL



PEUGEOT 307 2.0 HDI (2001 - 2010)



I-397 \$ 43.862

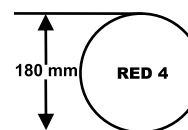

SIN BAÚL

S-397 G \$ 114.899



CON BAÚL

S-397/1G \$ 118.396



PEUGEOT 408 1.6 16V (2015 - 2021)



S-40 G \$ 70.709

I-396/1 \$ 45.791

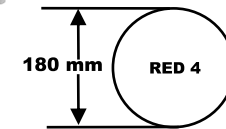

S-397/3G \$ 115.898



RENAULT

VEHICULO

PÁGINA

JEEP IKA - 4L - 4S - R6	1
R9 - R11 - SYMBOL	2
R12 - R18 - R21 - FUEGO	3/4/5
CLIO - CLIO II - TORINO	6/7/8/9
R19	10/11
EXPRES - TWINGO	12
MEGANE	13/14
OROCH - KWID - FLUENCE	15
DUSTER	16
LOGAN - SANDERO - MASTER - LAGUNA	17/18
TRAFIC - KANGOO	19/20/21



MUSSIO ESCAPES





JEEP IKA

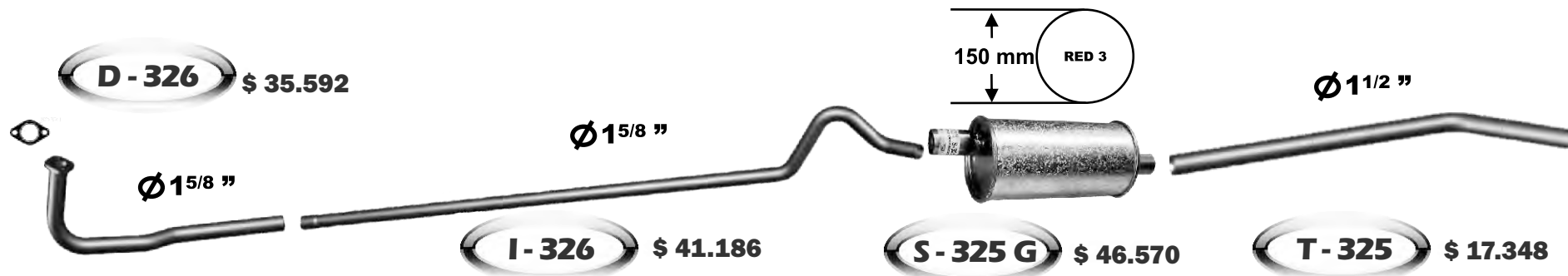

RENAULT 4L - 4S

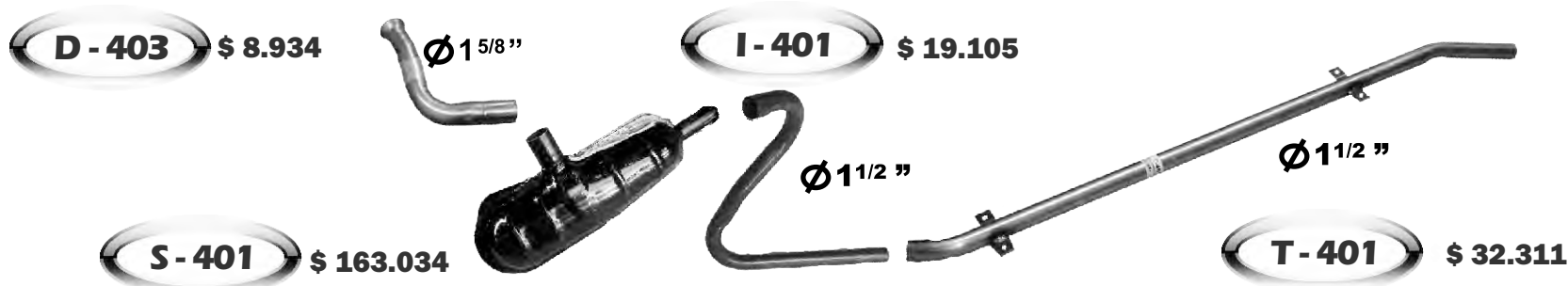

RENAULT R6 (1972 - 1983)





RENAULT R9 TXE (1988 - 1993) - 1.6 (1987 - 1996)

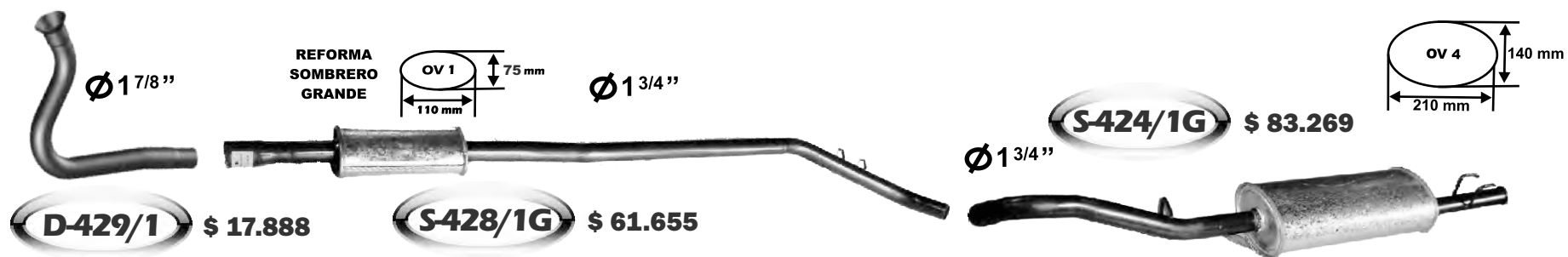

RENAULT R11 TS (1988 - 1993) - 1.6 (1987 - 1995)



RENAULT SYMBOL 1.6 16V (2009 - 2013)





RENAULT 12 1400 - Caja de 4ta. (1978 - 1987)



RENAULT 12 1600 - Caja de 5ta.

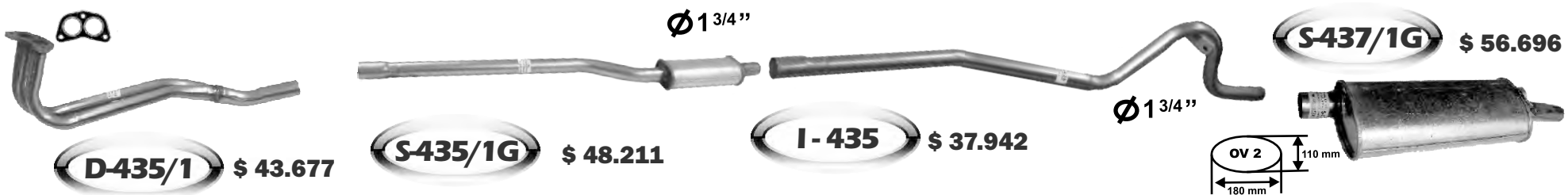

RENAULT 12 1600 - Caja de 5ta. Break

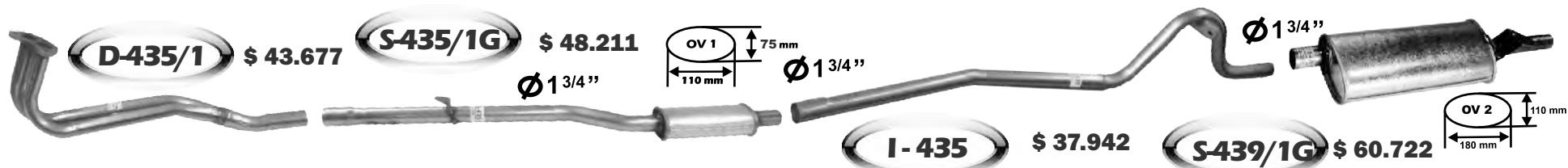



RENAULT 18 - BREAK GTX (1982 - 1993)

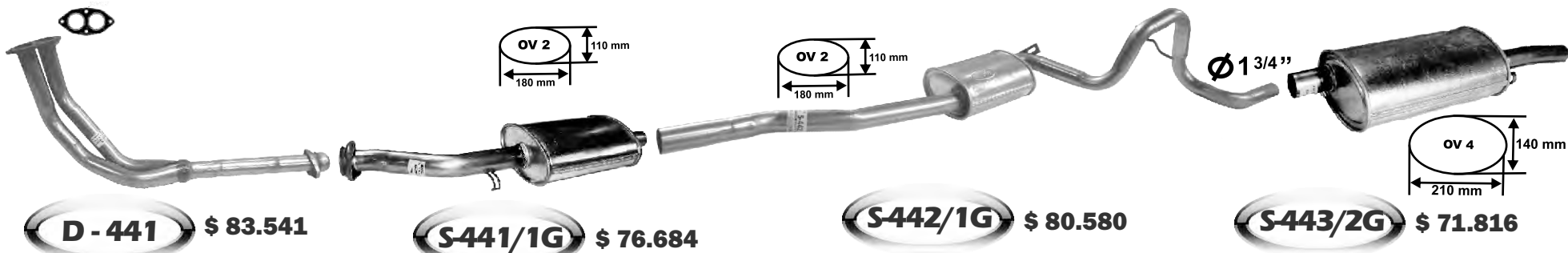

RENAULT 18 1400 (1984 - 1988)

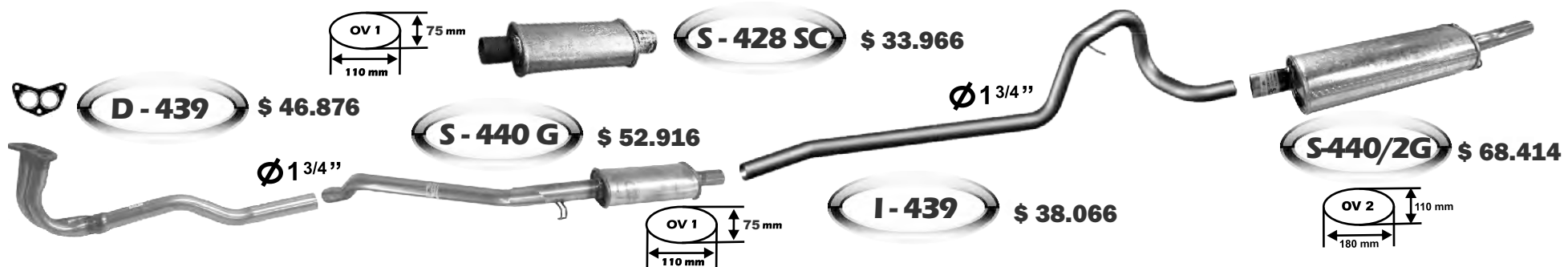

RENAULT 18 1.6 Paragolpe Envolvente (1989 - 1991)

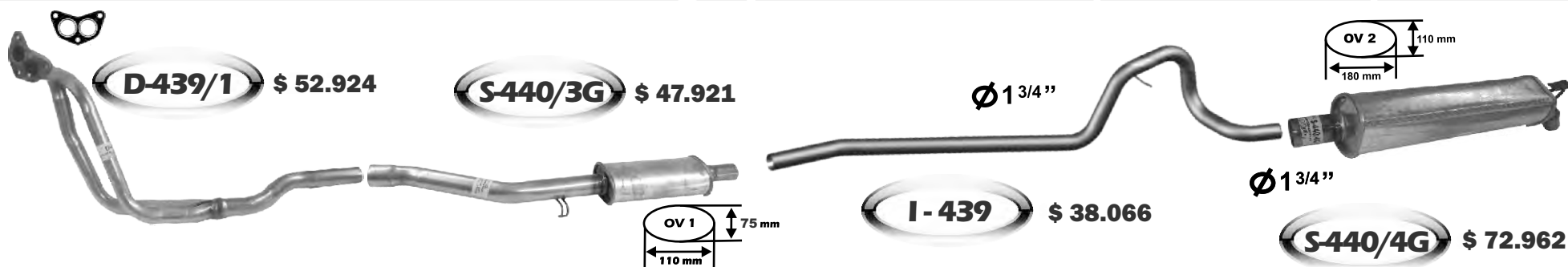



RENAULT FUEGO (1983 - 1989) - GTA MAX (1990 - 1993)

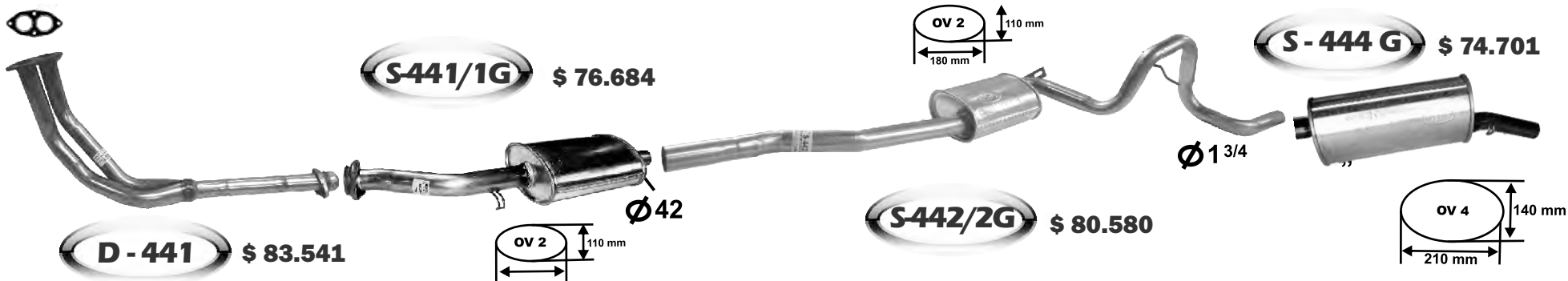

RENAULT 21 TXE (Coche) NAFTERO 2.0 - 2.2 (1989 - 1995)

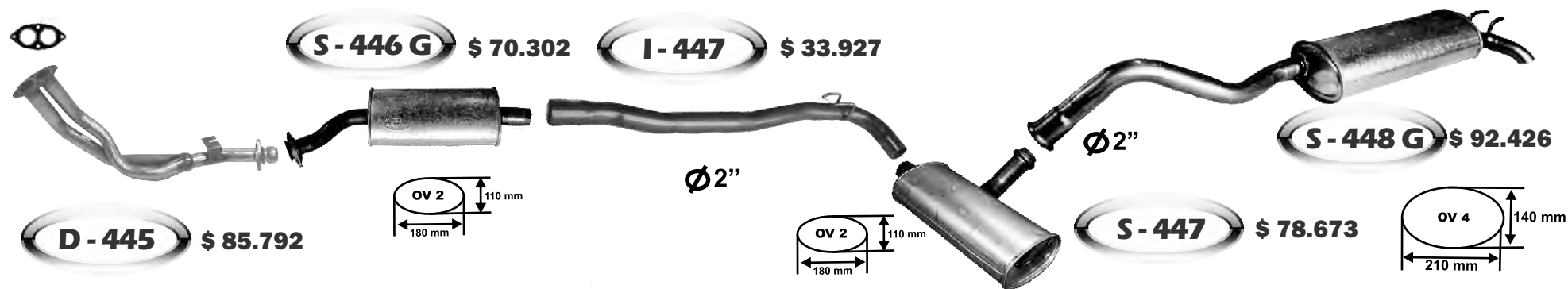

RENAULT 21 TXE (Nevada) NAFTERO 2.0 - 2.2 (1990 - 1996)

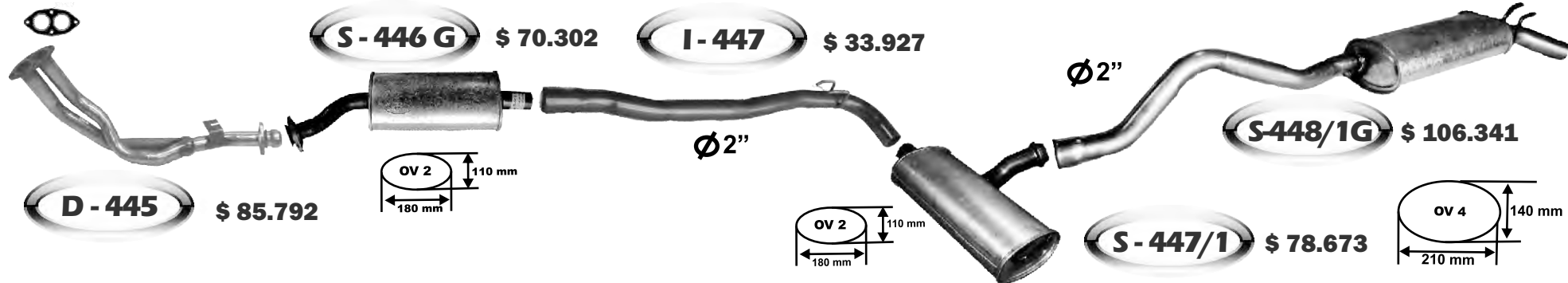



RENAULT CLIO DIESEL IMPORTADO - 1.4i (1994 - 1999)

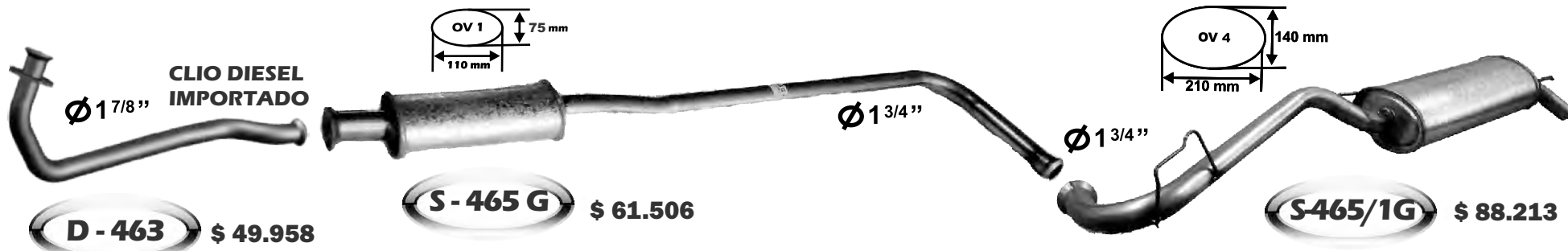

RENAULT CLIO Diesel 1.9 (1996 - 1999)



RENAULT CLIO II Diesel 1.5 DCI (2003 - 2009)





RENAULT CLIO MIO 1.2 (2012 - 2017)



RENAULT CLIO 1.4 i (1994 - 1999)



RENAULT CLIO 1.6i (1996 - 1999)

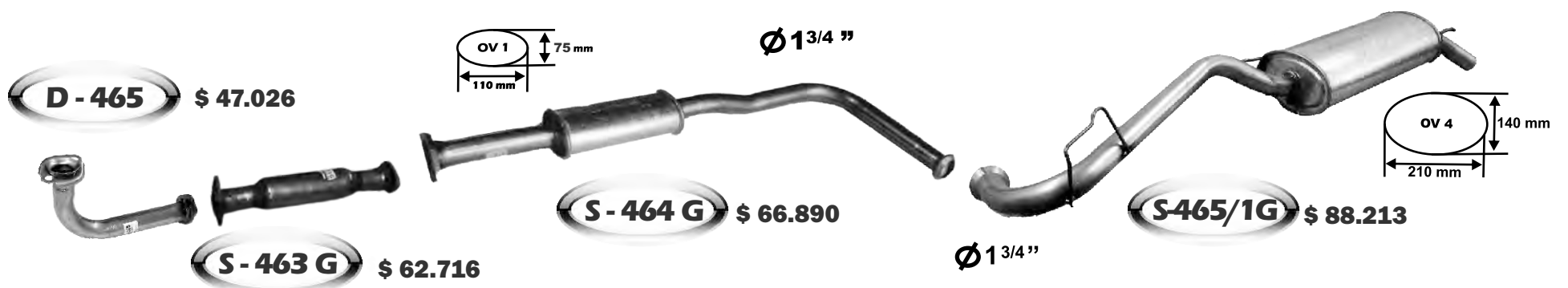



RENAULT CLIO II 1.2 16v (2003 - 2012) (Sin Baul)



D - 422 \$ 46.854

Tuerca sonda Lambda

Tuerca sonda lambda

S - 461/1 \$ 50.478

D-422/1 \$ 66.676

S-462/3G \$ 93.074

Sin Baúl



RENAULT CLIO II 1.6 16V (2000 - 2009)



D-462 M \$ 150.974

Malla de acero inoxidable

Reemplaza Catalizador

S - 461 G \$ 51.143

OV 1 75 mm

OV 4 140 mm

OV 4 210 mm

OV 4 140 mm

S-462/1G \$ 93.074

Sin Baúl

Con Baúl

S-462/2G \$ 97.070



RENAULT CLIO II 1.6 8V (2000 - 2003)



Tuerca sonda Lambda

OV 2 110 mm

OV 2 180 mm

OV 4 140 mm

OV 4 210 mm

D - 468 \$ 90.868

S - 462 G \$ 73.222

S-462/1G \$ 93.074

Sin Baúl

Con Baúl

S-462/2G \$ 97.070



RENAULT CLIO II Diesel 1.9 (2000 - 2003)



D-421 M \$ 101.051

Malla de acero inoxidable

S-462 G \$ 73.222

$\Phi 1\frac{3}{4}$ "

S-462/1G \$ 93.074

S-462/2G \$ 97.070

D-423 \$ 195.020

RENAULT CLIO II 1.5
SALIDA DE TURBO CON REEMP. CAT

RENAULT TORINO 7 BANCADAS GS - GR (1974 - 1982)



D-493 \$ 106.827

I-493 \$ 64.103

S-493 G \$ 115.381

$\Phi 2\frac{1}{4}$ "

$\Phi 2$ "

RENAULT TORINO TSX 7 BANCADAS (1976 - 1982)



D-494 \$ 133.405

I-494 \$ 58.195

S-496 G \$ 139.393

$\Phi 2$ "

$\Phi 2$ "



RENAULT R 19 RN (1992 - 1994) (Sin Baul)

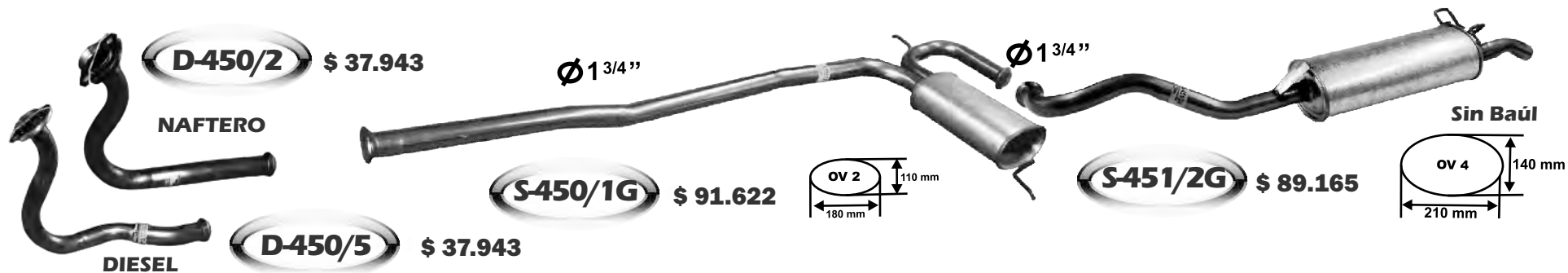

RENAULT R 19 RT 1.7 (1992 - 1994) (Con Baul)



RENAULT R 19 1.6 i (1995 - 1997) (Con Baul)

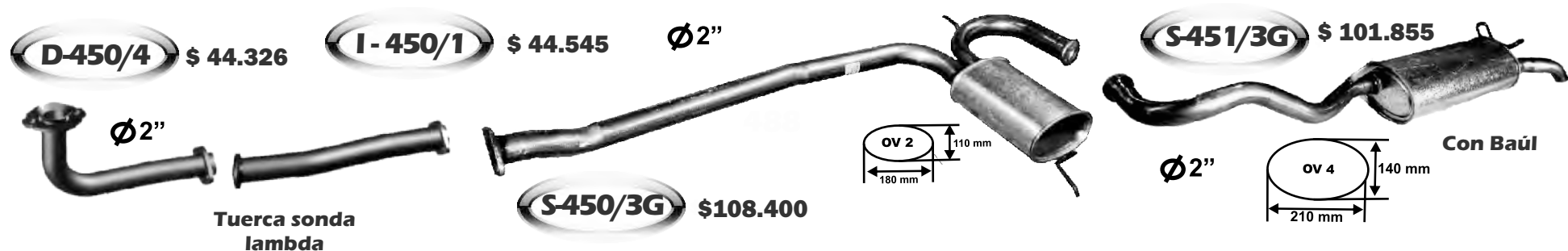



RENAULT R19 RT 1.8i (1995 - 1997) (Sin Baul)



D-450/6 \$ 49.292



\$ 49.292

Ø2"

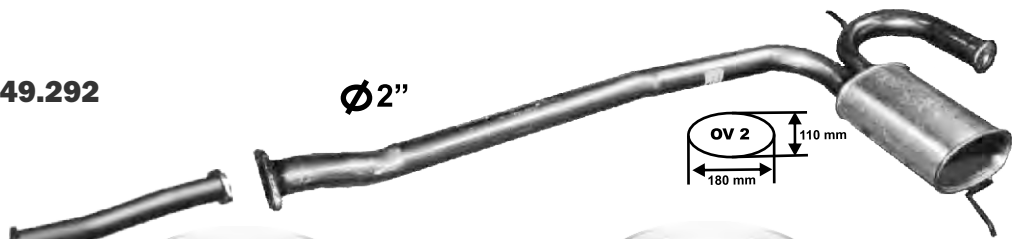

I-450 \$ 48.871

\$ 48.871

S-450/3G \$ 108.400

\$ 108.400

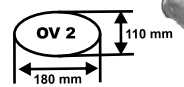

S-451/4G \$ 101.855

\$ 101.855

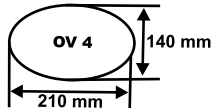

Sin Baul



RENAULT R19 RT 1.8i (1995 - 1997) (Con Baul)



D-450/6 \$ 49.292



\$ 49.292

Ø2"



I-450 \$ 48.871

\$ 48.871

S-450/3G \$ 108.400

\$ 108.400

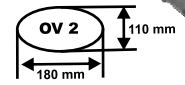

S-451/3G \$ 101.855

\$ 101.855

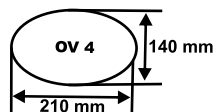

Con Baul



RENAULT R19 RN 1.6 i (1995 - 1997) (Sin Baul)



D-450/4 \$ 44.326



\$ 44.326

I-450/1 \$ 44.545

\$ 44.545

S-450/3G \$ 108.400

\$ 108.400

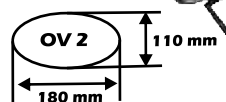

S-451/4G \$ 101.855

\$ 101.855

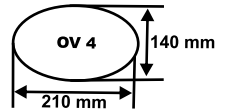

Sin Baul



RENAULT EXPRESS Diesel 1.9(1996 - 2000)

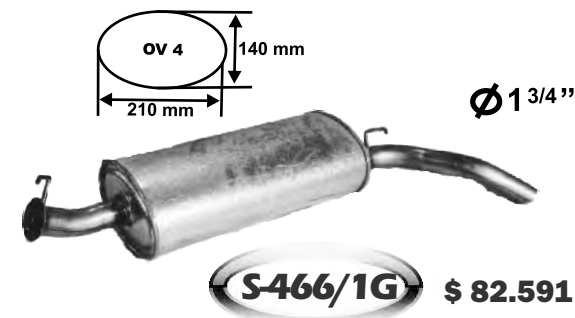
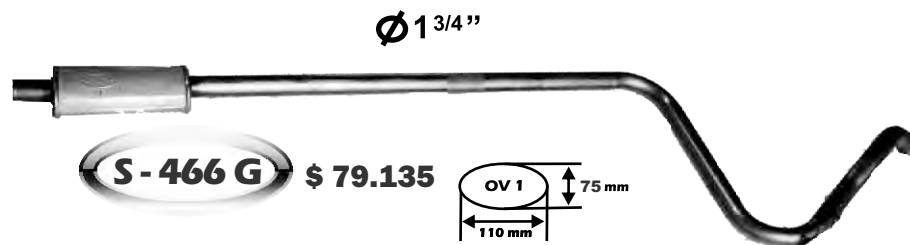

RENAULT EXPRESS RNI - D 55 1.9 (1996 - 2000)

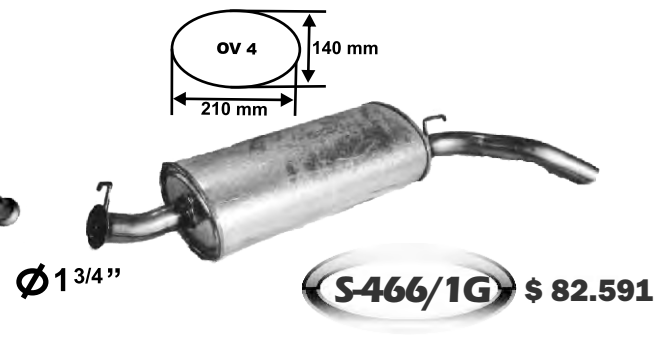

RENAULT TWINGO (1994 - 2001)





R MEGANE II 1.6 - 2.0 16V - 1.9 D - 1.5 DCI Con Baul (06 - 11)



Tuerca sonda lambda **D-470 M** \$ 148.562

Malla de acero inoxidable **D-423** \$ 195.020 **CLIO 1.5 DCI**

S-470 G \$ 83.899

S-470/1G \$ 101.709



RENAULT MEGANE RT 1.6i (1997-1999)



Tuerca sonda Lambda **D-468** \$ 90.868

Malla de acero inoxidable **S-469 M** \$ 134.038

Reemplaza Catalizador **S-468/1G** \$ 108.983

$\Phi 2''$



RENAULT MEGANE RT - RXE y SCENIC 2.0i (97-2004)



RECA-469 \$ 83.911 **S-469/1** \$ 80.431 **Estampado**

Malla de acero inoxidable **D-469 M** \$ 125.779 **Reemplaza Catalizador** $\Phi 2''$

Turbo **S-469/1E** \$ 57.801 **S-468/1G** \$ 108.983

$\Phi 2''$



RENAULT MEGANE 1.9 TD (97-09) y SCENIC 1.9 TD (00 - 11)



RECA-469/1 \$ 57.419

S - 469/1 \$ 80.431

Estampado

S-469/1E \$ 57.801

S-469/1G \$ 70.173

Turbo

S-468/1G \$ 108.983

2 SOPORTES

D-469/2M \$ 111.916

Galvanizado

Ø 2"

Ø 2"

Ø 2"

Malla de acero inoxidable

OV 4

140 mm

210 mm



RENAULT MEGANE 1.6 16V (00 - 09) y SCENIC 1.6 - 2.0 16V (01-11)



S - 469/2 \$ 76.781

Estampado

S-469/2E \$ 50.949

Turbo

S-468/3G \$ 108.652

D-469/1M \$ 150.974

Galvanizado

S-469/2G \$ 67.095

Malla de acero inoxidable

OV 4

140 mm

210 mm

Ø 2"



RENAULT OROCH 1.6 - 2.0 16V (2016 - 2022)

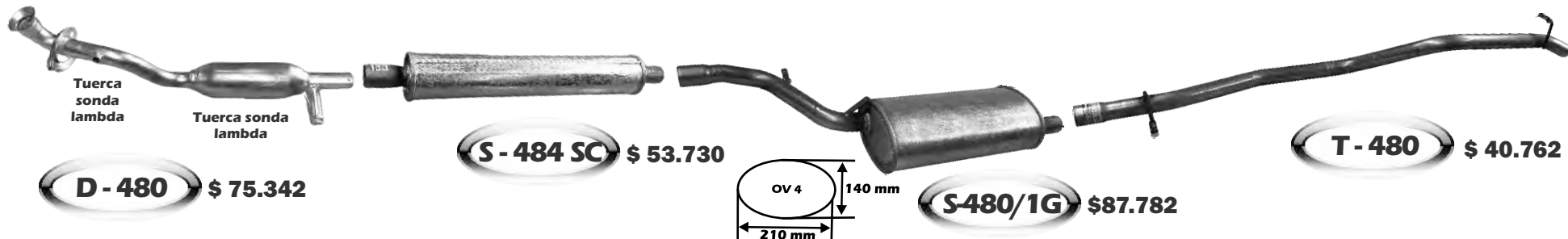

RENAULT KWID 1.0 (2017->)



RENAULT FLUENCE 2.0 (2010 - 2018)





RENAULT DUSTER 1.6 16V (2012 - 2020)

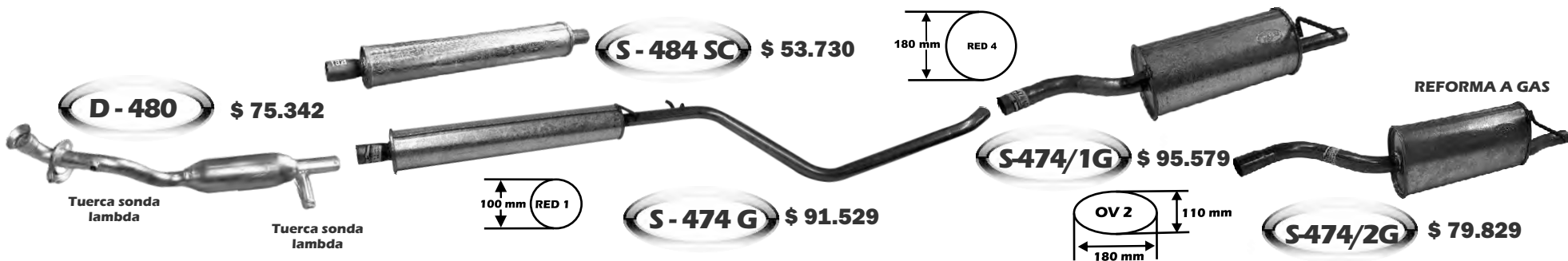

RENAULT DUSTER 2.0 16V 4X2 (2012 - 2022)

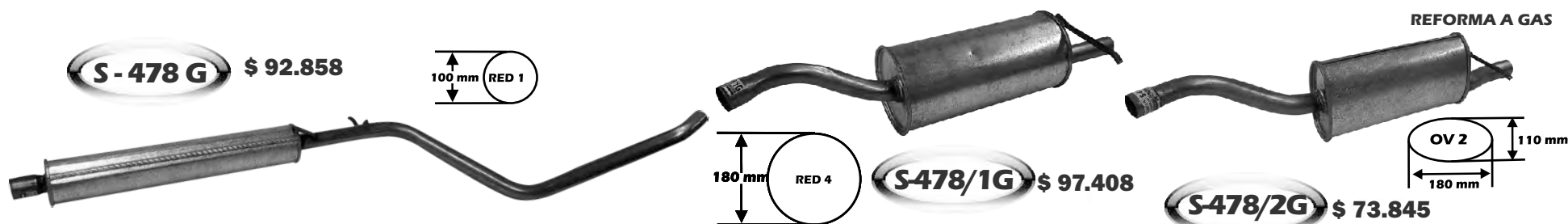

RENAULT DUSTER 2.0 4X4 (2012 - 2018)

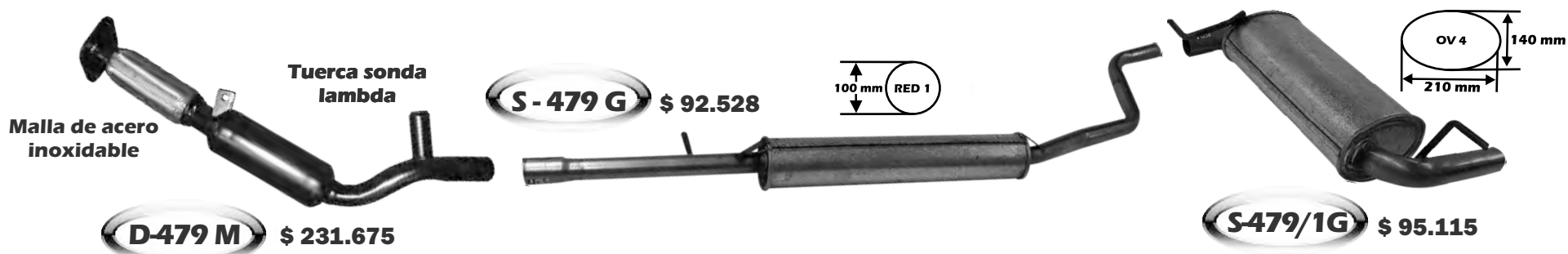



RENAULT LOGAN 1.6 8V-16V (2008-2013)

D - 484 \$ 85.266 **S-484 SC** \$ 53.730 Delantero Logan sin caños

Tuerca sonda lambda Reemplaza Catalizador

D-484/1 \$ 40.706

100 mm RED 1

180 mm RED 4

Salida Logan-Sandero 1.6 8v 2013-> **S - 484 G** \$ 91.859 **S-484/1G** \$ 95.909

RENAULT SANDERO 1.6 16V (2008 - 2013)

Reemplaza Catalizador Tuerca sonda lambda

100 mm RED 1

D - 483 \$ 75.967 **S - 483 G** \$ 91.859 **S-483/1G** \$ 96.524

RENAULT LOGAN 1.6 8V-16V - SANDERO 1.6 8V-16V (13-19)

Reemplaza Catalizador Tuerca sonda lambda

S - 485 G \$ 80.438 **S-485/1G** \$ 88.241

100 mm RED 1

180 mm RED 4

D - 483 \$ 75.967 **S-483/2G** \$ 79.829

OV 2 110 mm 180 mm

Reforma a Gas (2008-2013)



RENAULT MASTER 2.8 (2003 - 2007)



S - 509 G \$ 86.729

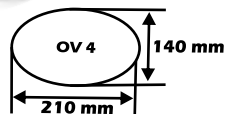

S - 510 G \$ 122.024

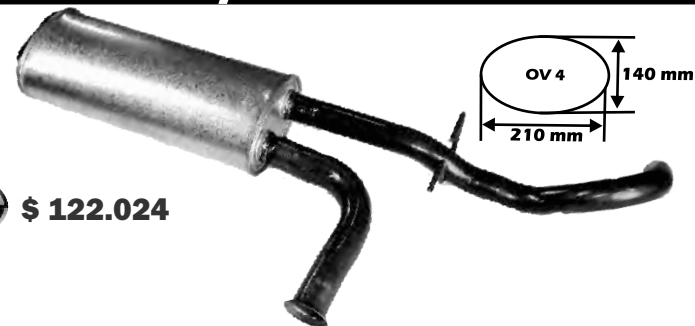

RENAULT LAGUNA 1.8 (99 - 02) y Diesel 2.2 (96 - 98)



S467/3G \$ 102.707

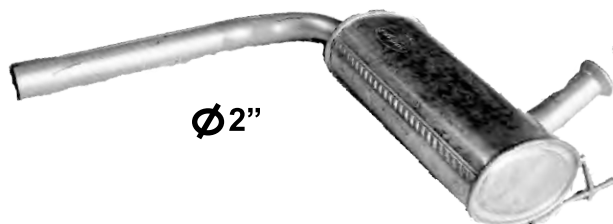
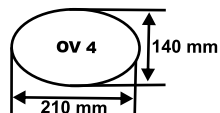

Ø2"

S467/2G \$ 99.986

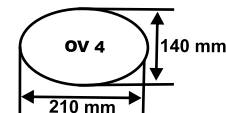

RENAULT LAGUNA 2.0 RXE (1995 - 2002)





RENAULT TRAFIC 2.0 Naf y Diesel



D - 501 \$ 84.733

S - 500 G \$ 57.456

I - 501 \$ 40.721

S - 504 G \$ 74.732



RENAULT TRAFIC 1.9 Diesel (1999 - 2003)



D - 505 \$ 41.156

S - 505 G \$ 76.556

S - 506 G \$ 102.225

S - 507 G \$ 80.351

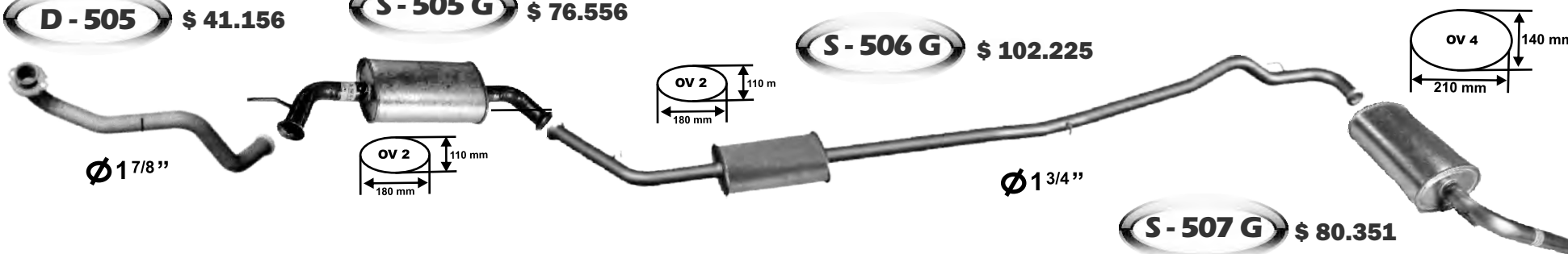

RENAULT TRAFIC 1.4



D - 500 \$ 57.918

S - 500 G \$ 57.456

I - 500 \$ 32.648

S - 502 G \$ 68.989





RENAULT KANGOO 1.2 (2001 - 2002)



RENAULT KANGOO 1.6 I 8V (1998 -2008) - 1.4 (1998-2000)

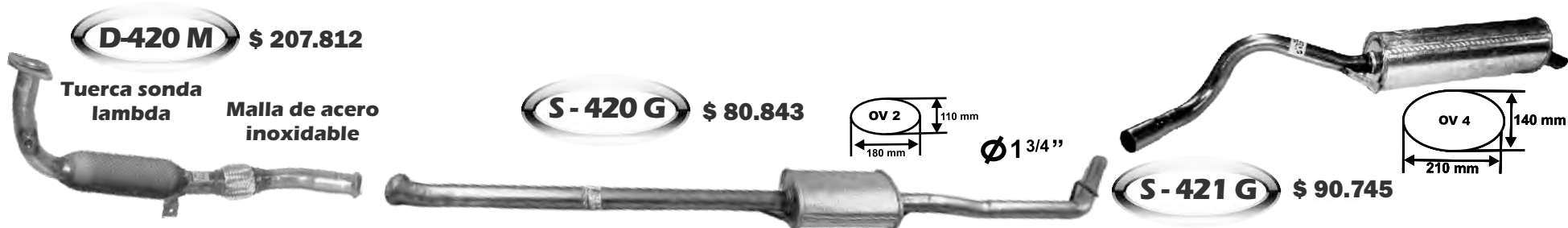

RENAULT KANGOO 1.6 8V (98-08) 1.4 (98-00) 1.6 16V (05-18)

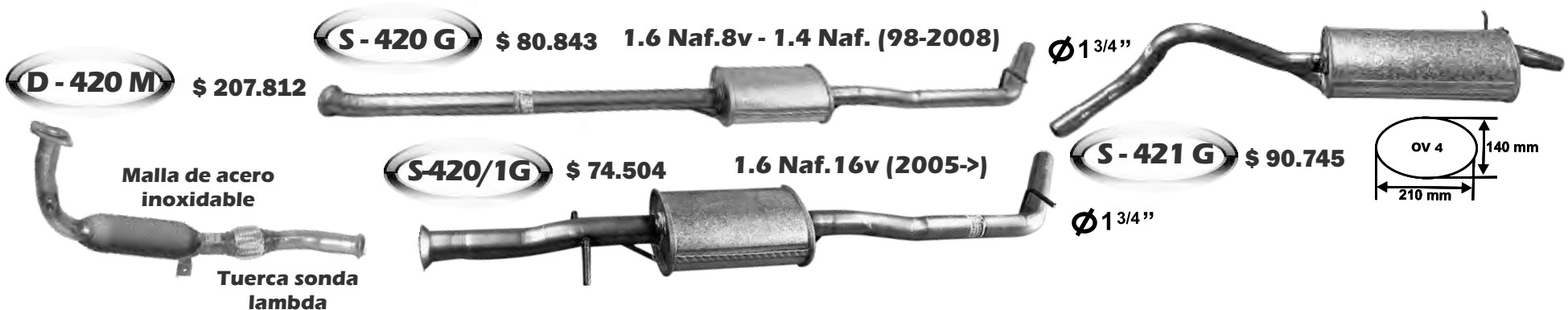



RENAULT KANGOO II 1.6 SCE (18->)



D 420/4 \$ 75.342

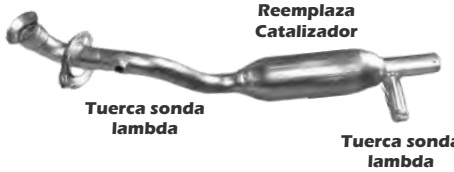

S-420/4G \$ 64.415

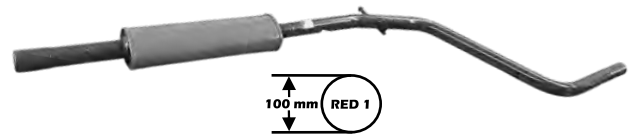

S-421/4G \$ 93.992

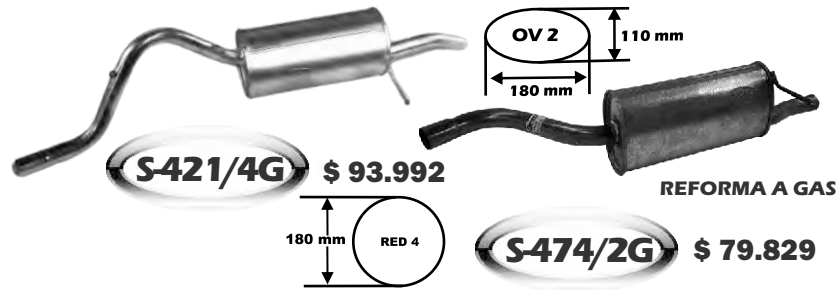

S-474/2G \$ 79.829



RENAULT KANGOO 1.9 Diesel (1999 - 2008)



D-421 M \$ 101.051



Ø 1 3/4" OV 2 110 mm 180 mm

S-420 G \$ 80.843



S-421 G \$ 90.745



RENAULT KANGOO SIL. PARA REFORMAS CON TUBOS DE GAS



S-421/1G \$ 78.433 Reforma a Gas 2017

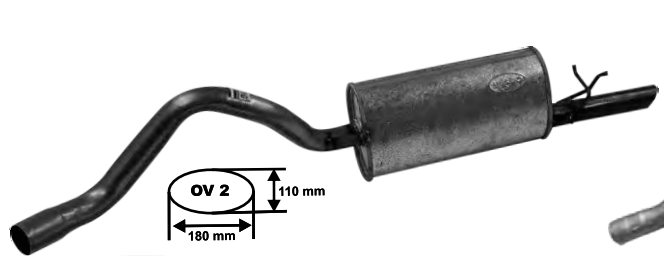

S-421/2G \$ 74.444

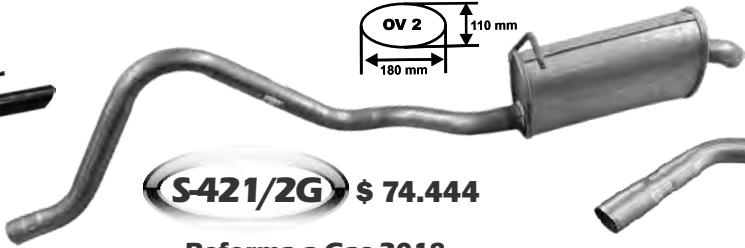

Reforma a Gas 2018

S-421/3G \$ 85.104



Reforma a Gas Para 2 tubos grandes



Volkswagen

VEHICULO

PÁGINA

DODGE 1500 - D 200 - RASTROJERO	1
ESCARABAJO - COMBI - GACEL	2
SAVEIRO	3
GOL - GOL TREND	4 A 7
VOYAGE - GOLF	8
POLO - CADDY	9
POINTER - SURAN	10
BORA - UP - AMAROK	11/12

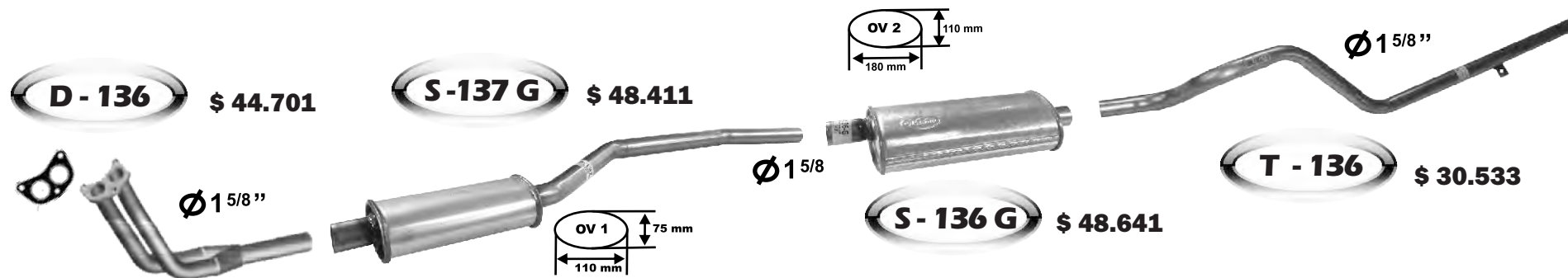
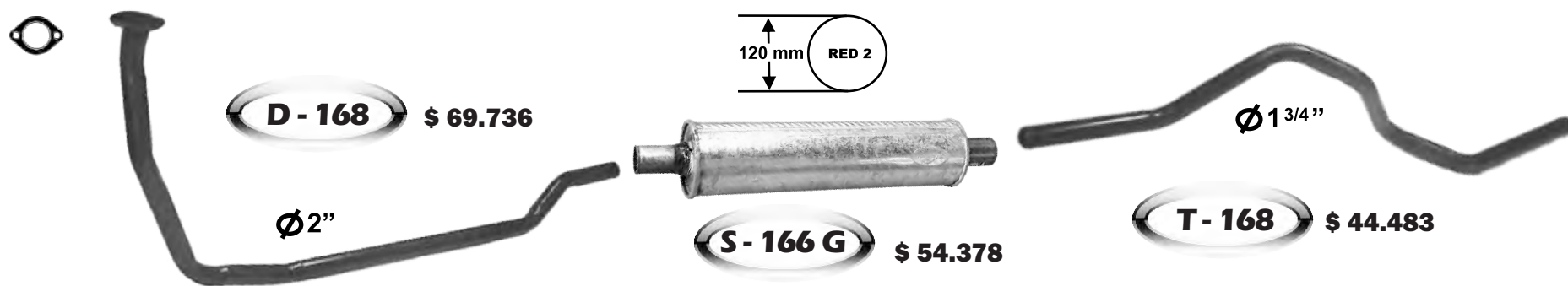
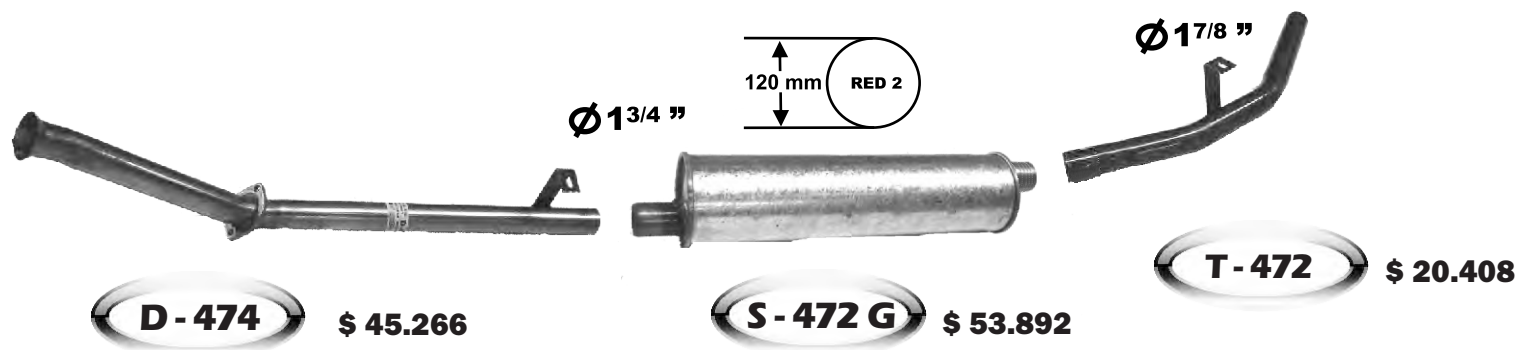

DODGE 1500 (1973 - 1982) - VW 1500 (1983 - 1992)

DODGE PICK UP - D200 Diesel

RASTROJERO INDENOR

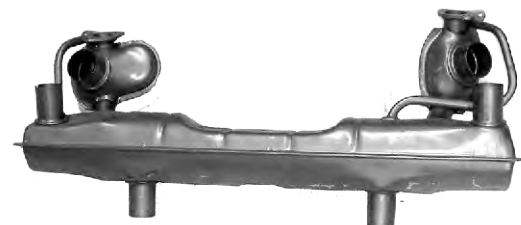

ESCARABAJO



S - 531 \$ 385.140



COMBI



S - 530 \$ 385.140



VW GACEL GL - SENDA 1.6 (1983 - 1995)

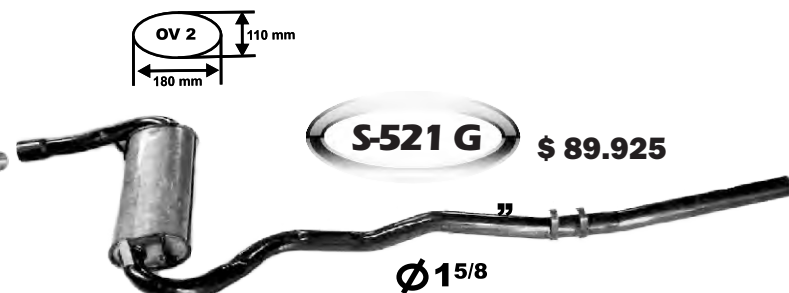
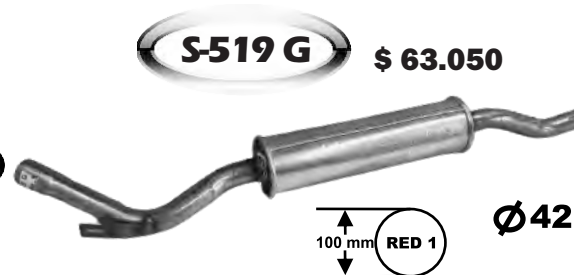

VW GACEL Y SENDA DIESEL (1990 - 1995)

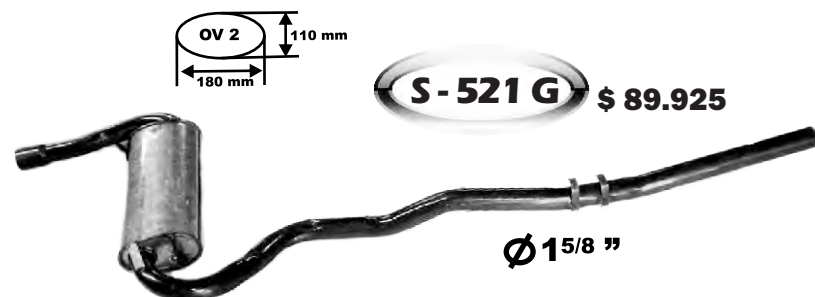

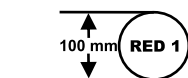
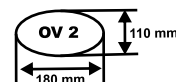

VW SAVEIRO 1.6 NAFTERA (1992 - 1996)

D - 540 \$ 85.218

S - 540 G \$ 69.471

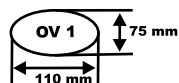
S - 521 G \$ 89.925

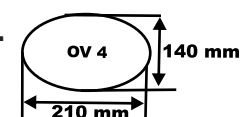
 $\varnothing 1\frac{5}{8}$ "

VW SAVEIRO 1.6 - 1.9 DIESEL (1997 - 2000)

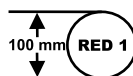
S - 546 G \$ 78.181

S - 547 G \$ 100.691

VW SAVEIRO 1.6 NAFTERA (2010 - 2022)

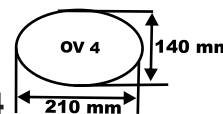
D-559 SCM \$ 104.286

I - 548 \$ 32.949

S - 548 G \$ 60.803

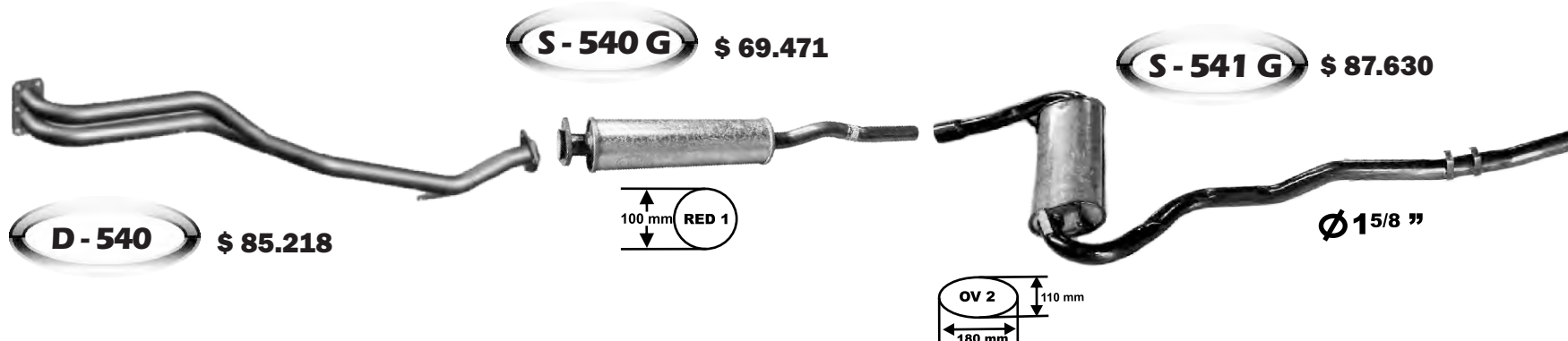
S-548/1G \$ 98.414

 **VW GOL 1.6 (MOT. RENAULT) BRASILEIRO NAF. (1991 - 1992)** 



 **VW GOL 1.6 (MOT. AUDI) NACIONAL (1993 - 1995)** 

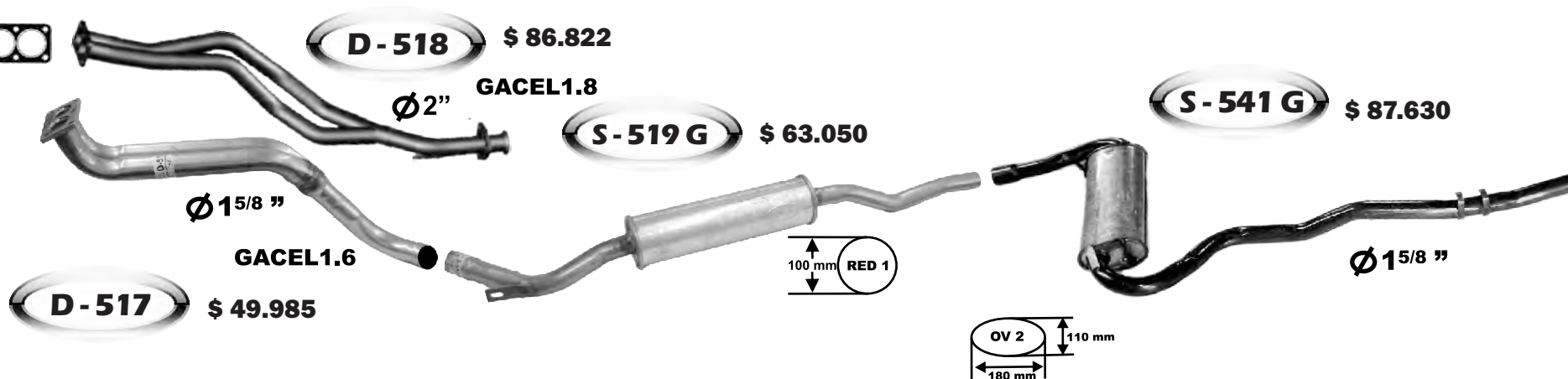



VW GOL 1.0 INYECCION (2000 - 2002)



VW GOL GLI 1.6 i (1996 - 1998)

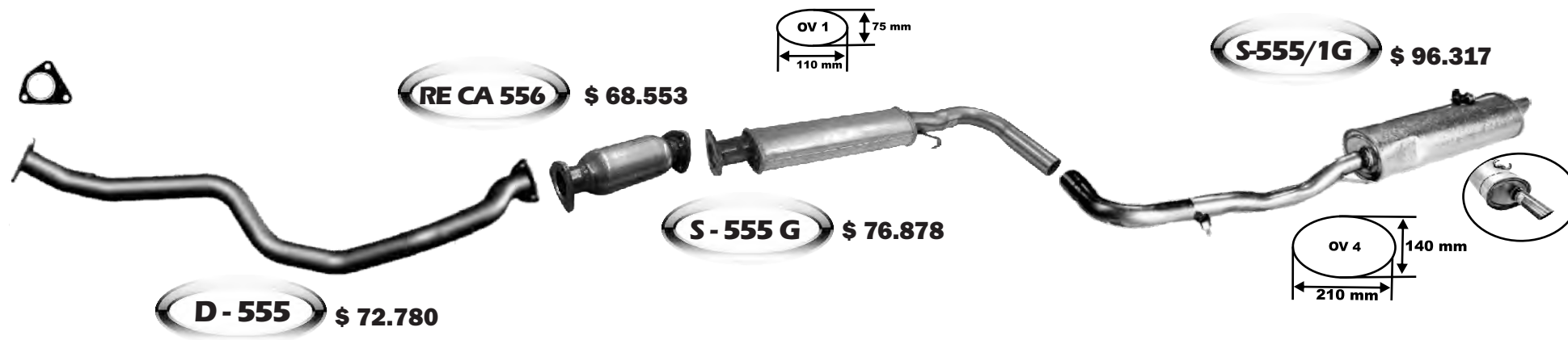

VW GOL 1.6 DIESEL (1996 - 1999)

D-554 M \$ 123.499 **RE CA 554** \$ 64.336 **S-554 G** \$ 74.934 **S-555/1G** \$ 96.317

D-554/1M \$ 135.811 **GOL DIESEL 1.9 (1998 - 2011)**

Malla de acero inoxidable

Malla de acero inoxidable

Ø 1 5/8"

OV 1 75 mm 110 mm

OV 4 140 mm 210 mm

2"

150 mm

VW GOL POWER 1.4 (2012 - 2015)

D-553 \$ 96.363 **S-557 G** \$ 78.093 **S-555/5G** \$ 92.675

Tuerca sonda lambda

Reemplaza catalizador

OV 1 75 mm 110 mm

OV 4 140 mm 210 mm

VW GOL 1.8i (1996 - 1998)

D-556 \$ 90.172 **RE CA 556** \$ 68.553 **S-555 G** \$ 76.878 **S-555/1G** \$ 96.317

Tuerca sonda Lambda

OV 1 75 mm 110 mm

OV 4 140 mm 210 mm

65mm

2"

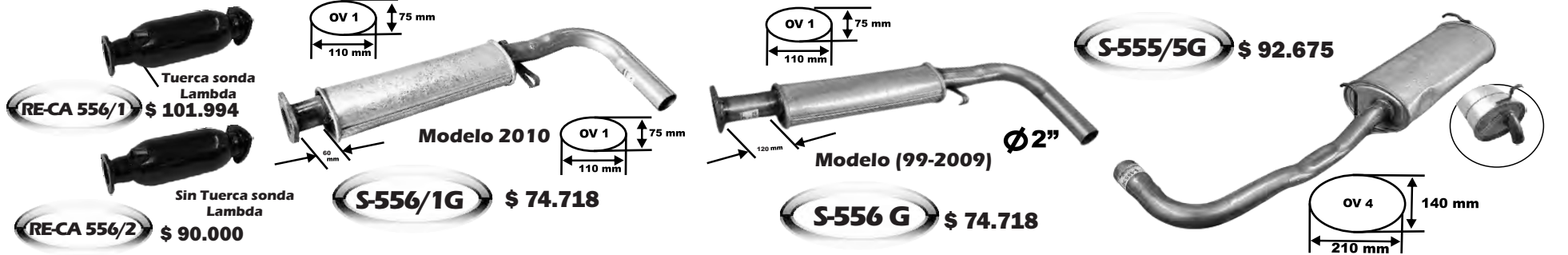
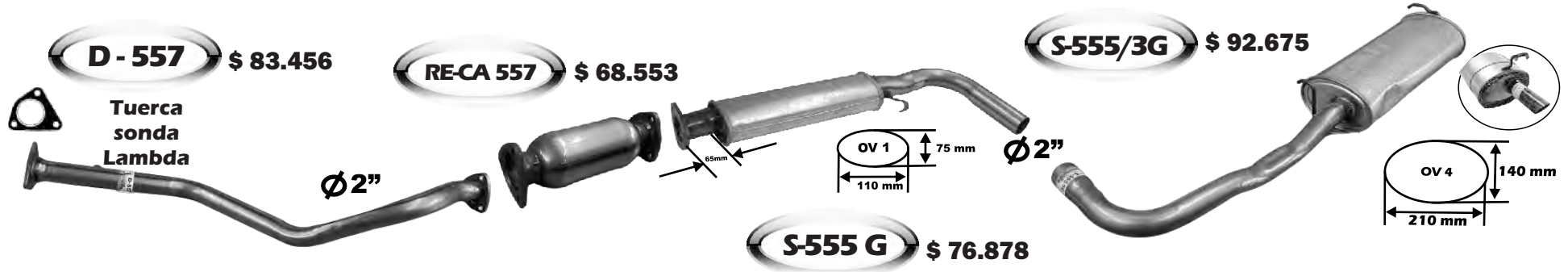
VW GOL 1.6 NAFTERO - POWER (99 - 09)

VW GOL POWER 1.6 MI (1998 ->)

VW GOL TREND 1.6i NAFTERO (2008 - 2022)



VW VOYAGE 1.6 (2007 - 2020)



D-559 SCM \$ 104.286 **S-548 G** \$ 60.803 **I-556** \$ 33.060

Tuerca sonda Lambda Malla de acero inoxidable

100 mm RED 1

OV 4 140 mm 210 mm

S-555/7G \$ 89.120



VW GOLF GTD DIESEL 1.9 (1996 - 1999)



Tuerca sonda Lambda

Tiene 2 Soportes (Golf 1.8 - 2.0)

D-560 \$ 95.609 **S-560 G** \$ 74.086 **I-560** \$ 23.220

OV 2 110 mm 180 mm

OV 2 110 mm 180 mm

Ø 2"

S-560/1G \$ 97.462



VW GOLF IV 1.6 INYECCION (1999 - 2012)



100 mm RED 1

OV 4 140 mm 210 mm

Ø 1 3/4"

S-561 G \$ 71.042 **S-561/1G** \$ 103.975

Cola Doble

VW POLO DIESEL 1.9 (1996 - 2009)



VW POLO NAFTERO 1.6 i (1997 - 2009)

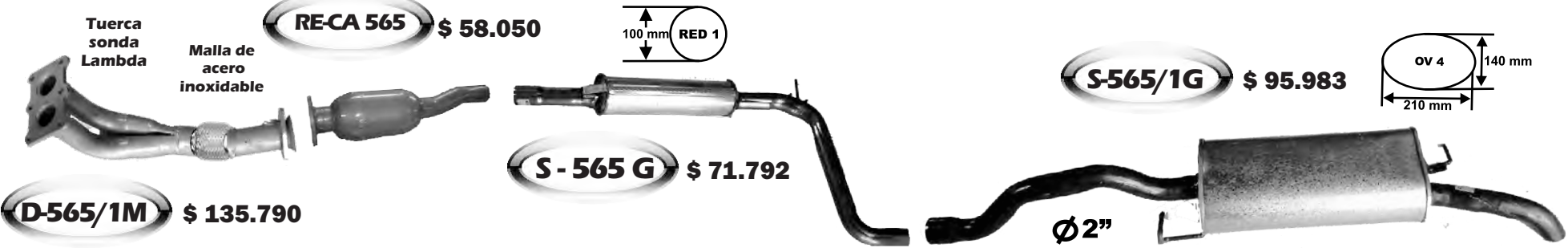

VW CADDY (1998 - 2009)

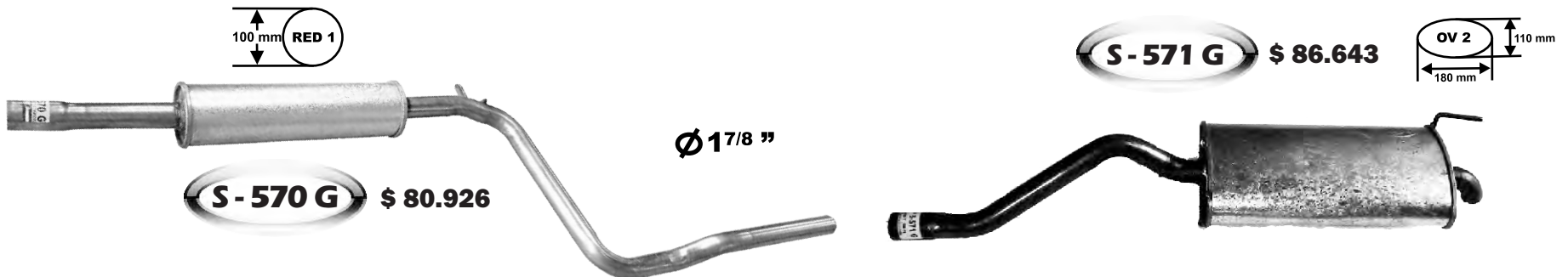



VW POINTER AUDI 1.6i - 1.8 - 2.0i (1995 - 1996)



D - 550 F \$ 84.890
S-550/1G \$ 104.636
S-550/2G \$ 87.842

FIJA SIN MALLA
 Tuerca sonda Lambda
 Malla de acero inoxidable
 Tuerca sonda Lambda

RE-CA 556 \$ 68.553
D - 550 M \$ 147.314

OV 2 110 mm 180 mm
 Ø2"
 OV 4 140 mm 210 mm



VW FOX - SURAN 1.6 8V NAF. (06 - 11) Y DIESEL 1.9 (06 - 10)



FOX - SURAN - CROSS FOX 1.6 (2004 - 2010)

Malla de acero inoxidable
D - 590 M \$ 262.883
S - 589 G \$ 70.234
S - 590 G \$ 98.357

100 mm RED 1
 INTERMEDIA LARGA
I - 590 \$ 48.868

FOX - SURAN - CROSS FOX 1.6 (2010 - 2019)

Tuerca sonda Lambda
 Malla de acero inoxidable
D-559 SCM \$ 104.286
S - 548 G \$ 60.803
I - 589 \$ 29.732
 CUERPO LEGITIMO
S - 590 O \$ 120.710

OV 4 140 mm 210 mm
 Ø2"



VW BORA 1.8 TURBO (2003 - 2015)



VW BORA 1.9 - 2.0 TDI (2000 - 2015)



VW UP 1.0 (2014 - 2021)





VW AMAROK 2.0 TDI (10→)

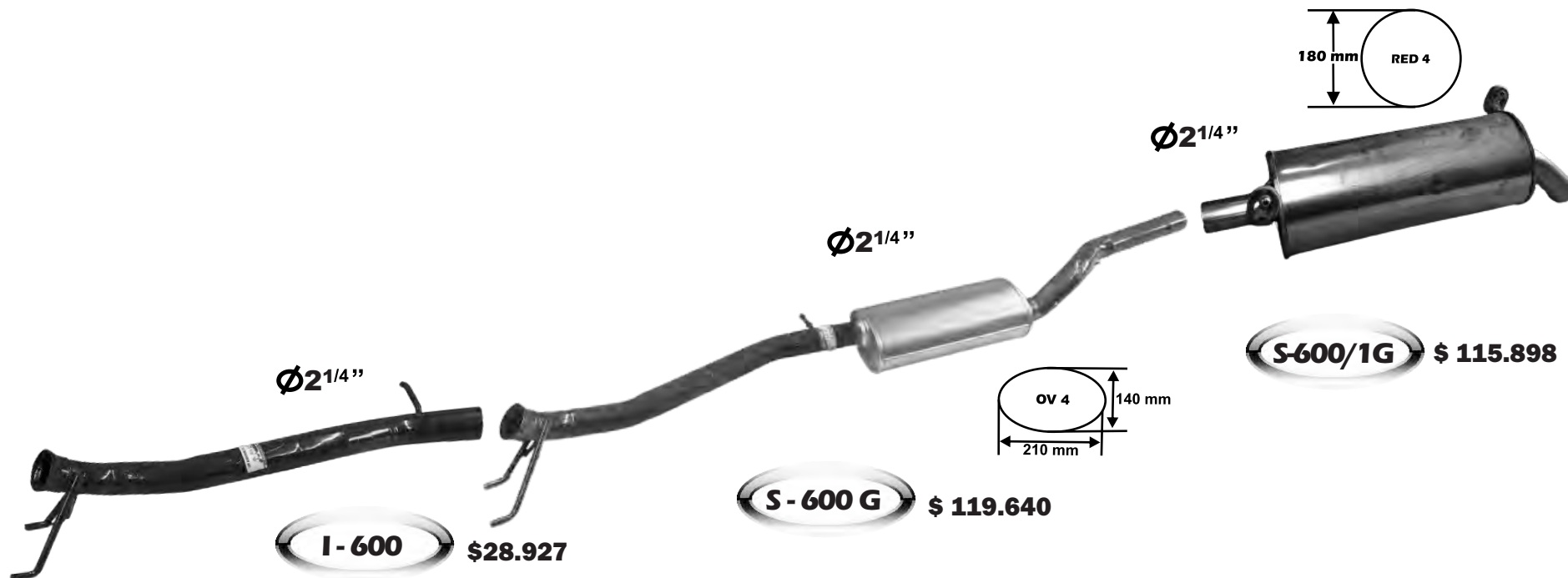

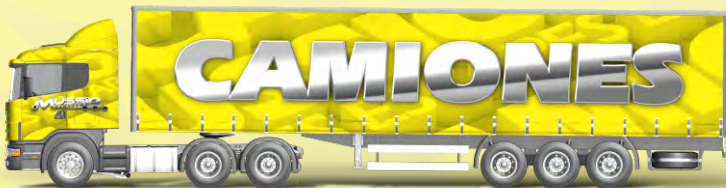

Mercedes-Benz



CHERY



ISUZU

Mercedes-Benz



TOYOTA



DODGE



HONDA

CAMIONES

PÁGINA

DODGE - FIAT

1

FORD

2

MERCEDES - BENZ - FORD 14000

3/4

COLAS - CURVAS - FLEXIBLES

5

IMPORTADOS

PÁGINA

MERCEDES - BENZ

6

CHERY - HONDA

7

ROVER - DODGE - TOYOTA

8

ALFA ROMEO - KIA - ISUZU

9

TOYOTA PICK UP

10/11





Dodge

DODGE DP 400 C/P 6/354

Dodge



FIAT

FIAT DAILY 4910 TURBO

FIAT



FIAT

FIAT IVECO

FIAT





FORD F - 350



D - 1299 \$ 57.143



I - 1299 \$ 34.371

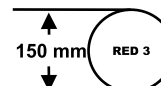

S-283 G \$ 60.582

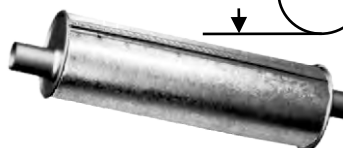

T - 285 \$ 19.783



FORD - CP 6/305 (1973 - 1983)



VACIO - LARGO 600 mm -
TAPA 160 mm - BOQ. 2 1/8"

D - 1297 \$ 66.634



S-1002 \$ 56.616



T - 1002 \$ 48.654



FORD - C/P 6354 (1966 - 1972)



VACIO - LARGO 600 mm -
TAPA 160 mm - BOQ. 2 3/8"

D - 1298 \$ 50.982



S - 1003 \$ 56.616



T - 1003 \$ 55.647





MERCEDES BENZ 1517



Ø3"
C-77 \$ 8.694
S-1006 V \$ 84.475 VACIO
T-1005 \$ 69.633
D-1335 \$ 76.402
Ø3" L: 900 mm - TAPA 180 mm - BOQ. 3 1/
I-1333 \$ 27.297
S-1006 O \$ 111.510 LLENO
 180 mm RED 4



MERCEDES BENZ 608



Ø2"
D-1332 \$ 47.860
S-1020 \$ 76.112
T-1332 \$ 40.770
 VACIO - LARGO 900 mm -
 TAPA 150 mm - BOQ. 2 1/8"



MERCEDES BENZ 608 MODELO NUEVO



Ø2"
D-1332/1 \$ 47.860
S-1020 O \$ 97.396
T-1332 \$ 40.770
 LLENO - LARGO 900 mm -
 TAPA 180 mm - BOQ. 2 1/8"



FORD 14000



D-1300/1 \$ 72.846



MWM 229/6 SIN TURBO
BRIDA CUADRADA

D - 1300 \$ 56.757



MERCEDES BENZ 1114



D - 1331 \$ 68.279



I - 1330 \$ 10.692



Ø 2 1/2"

I - 1331 \$ 27.078

VACIO - LARGO 900 mm -
TAPA 150 mm - BOQ. 2 5/8"



LLENO - LARGO 900 mm -
TAPA 180 mm - BOQ. 2 5/8"



S - 1005 \$ 72.676

S-1005 O \$ 88.560



T - 1330 \$ 59.670

Ø 2 1/2"



MERCEDES BENZ 1215



D - 1337 \$ 96.394



LLENO - LARGO 900 mm -
TAPA 180 mm - BOQ. 3 1/2"

S-1007 O \$ 114.210



Ø 4"

T - 1007 \$ 127.980

COLAS Y CURVAS UNIVERSALES - FLEXIBLES CORRUGADOS



90°



90°



45°

CURVAS 90° (1000 mm X 1000 mm)

T 1002 - CAÑO 2"	\$ 48.654
T 1003 - CAÑO 2 1/4"	\$ 55.647
T 1004 - CAÑO 2 1/2"	\$ 60.642
T 1005 - CAÑO 3"	\$ 69.633
T 1006 - CAÑO 3 1/2"	\$ 100.143
T 1007 - CAÑO 4"	\$ 127.980
T 4500 - CAÑO 4 1/2"	\$ 174.636
T 5000 - CAÑO 5"	\$ 238.140

CURVAS A 90° (450 mm X 450 mm)

CU - 134 - CAÑO 1 3/4"	\$ 13.028
CU - 178 - CAÑO 1 7/8"	\$ 14.027
CU - 200 - CAÑO 2"	\$ 15.125
CU - 214 - CAÑO 2 1/4"	\$ 18.063
CU - 212 - CAÑO 2 1/2"	\$ 20.061
CU - 300 - CAÑO 3"	\$ 22.059
CU - 312 - CAÑO 3 1/2"	\$ 34.587
CU - 400 - CAÑO 4"	\$ 49.275
CU - 412 - CAÑO 4 1/2"	\$ 92.169
CU - 500 - CAÑO 5"	\$ 125.685

CURVAS A 45° (450 mm X 450 mm)

CU - 134 45 - CAÑO 1 3/4"	\$ 13.028
CU - 178 45 - CAÑO 1 7/8"	\$ 14.027
CU - 200 45 - CAÑO 2"	\$ 15.125
CU - 212 45 - CAÑO 2 1/2"	\$ 20.061
CU - 300 45 - CAÑO 3"	\$ 22.059
CU - 312 45 - CAÑO 3 1/2"	\$ 34.587
CU - 400 45 - CAÑO 4"	\$ 49.275
CU - 412 45 - CAÑO 4 1/2"	\$ 92.169
CU - 500 45 - CAÑO 5"	\$ 125.685

CAÑOS FLEXIBLES CORRUGADOS GALVANIZADOS (FRACCIONADOS X METRO)



F-134 - CORRUGADO DE 1 3/4" - 44,45 mm	\$ 57.355
F-200 - CORRUGADO DE 2" - 50,80 mm	\$ 74.941
F-214 - CORRUGADO DE 2 1/4" - 57,15 mm	\$ 85.534

F-212 - CORRUGADO DE 2 1/2" - 63,50 mm	\$ 98.809
F-300 - CORRUGADO DE 3" - 76,20 mm	\$ 107.271
F-312 - CORRUGADO DE 3 1/2" - 88,90 mm	\$ 120.888
F-400 - CORRUGADO DE 4" - 101,60 mm	\$ 134.564
F-412 - CORRUGADO DE 4 1/2" - 112 mm	\$ 145.540
F-500 - CORRUGADO DE 5" - 125 mm	\$ 172.323

IMPORTADOS



Mercedes-Benz

Página 6 - 11



MERCEDES BENZ SPRINTER 3 10 Diesel (1999 - 2000)



D - 700 \$ 123.228

$\text{Ø} 2\frac{1}{2}''$

S-700 G \$ 137.071

OV 4 140 mm
210 mm

Cola larga

T - 701 \$ 64.218

$\text{Ø} 2\frac{1}{2}''$

Cola corta

T - 700 \$ 51.231

$\text{Ø} 2\frac{1}{2}''$



MERCEDES BENZ 180D - PICK UP y COMBI



D - 800 \$ 48.875

$\text{Ø} 1\frac{3}{4}''$

S-800 OG \$ 92.880

OV 2 110 mm
180 mm

T - 800 \$ 44.439

$\text{Ø} 1\frac{3}{4}''$



MERCEDES BENZ CLASE "A"



S - 805 G \$ 115.036

OV 4 140 mm
210 mm

IMPORTADOS



Página 7 - 11



CHERY TIGGO NAFTERA 2.0 (11-16)



2 Tuercas sonda lambda
Malla de acero inoxidable

D-2200 M \$ 182.133

S-2200 G \$ 120.885

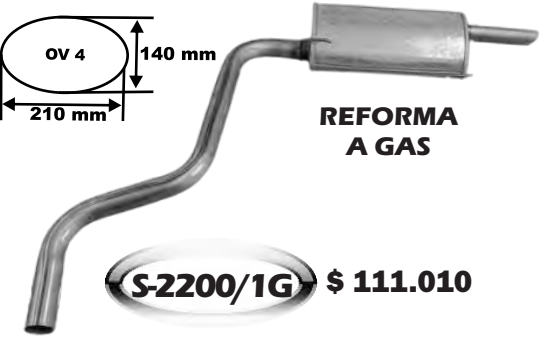
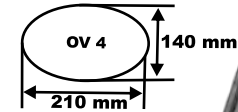
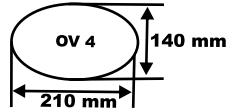

REFORMA A GAS

S-2200/1G \$ 111.010



CHERY QQ

CHERY TIGGO NAF. 2.0 (11-16)

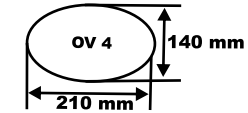

S-2220/1G \$ 112.503

2 Tuercas sonda lambda

D-2200/1M \$ 203.989



Malla de acero inoxidable

2.0 4x4 Luxury

D-2200 \$ 134.778



Con Reemplaza Catalizador



ACCORD EX - LX (92 - 96)

HONDA CIVIC

HONDA FIT

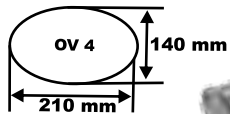

S-2401 G \$ 140.890

COLA DOBLE

S-2406 G \$ 103.845

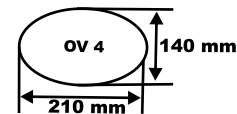

S-2405 G \$ 95.912

IMPORTADOS



Dodge **DODGE RAM**

ROVER 214 SLI - 216 SI - 414 SLI (94 - 99)

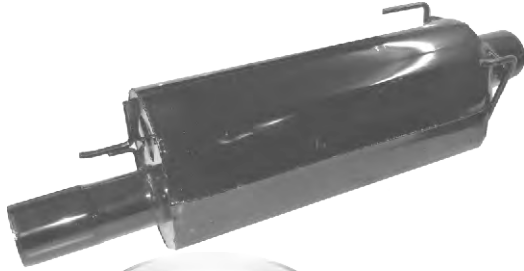

S - 2250 \$ 215.331



S - 2428 G \$ 119.209

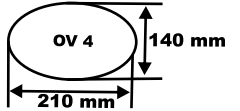

TOYOTA COROLLA 1.6 16V

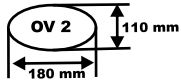

S - 2511 G \$ 79.704



S - 2512 G \$ 103.879

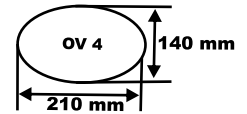

TOYOTA COROLLA (2002 ->)



S - 2513 \$ 83.934

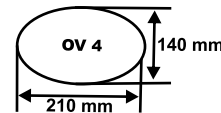

S-2513/1G \$ 127.185

IMPORTADOS



Página 9 - 11



ALFA ROMEO 145



S - 2000 G \$ 97.848



S - 2001 G \$ 99.846



KIA SPORTAGE - HYUNDAI TUCSON



S - 2300 \$ 180.000

ISUZU

ISUZU 2.5 (1995 - 1999)

ISUZU



D-2420 M \$ 175.951

DIESEL

**Malla de Acero
Inoxidable**

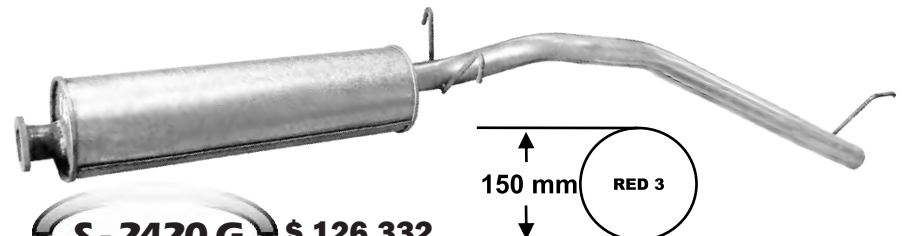

S - 2420 G \$ 126.332



TOYOTA PICK UP HILUX (1981 - 1983)

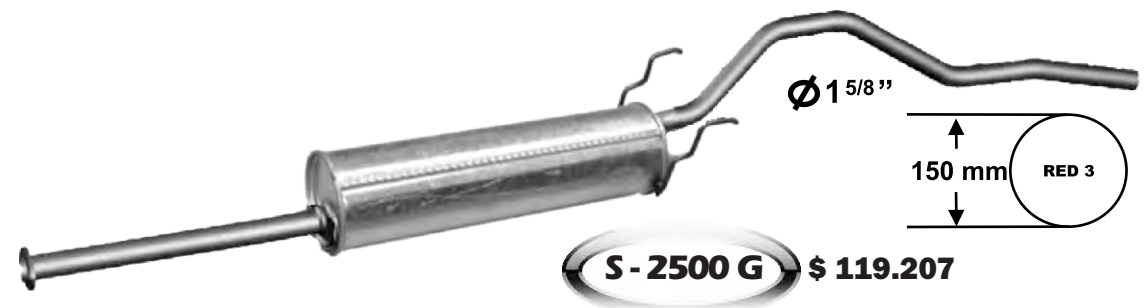
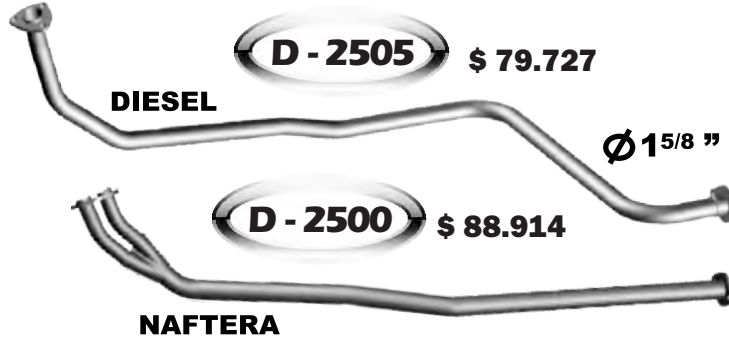

TOYOTA PICK UP HILUX 2.8 Diesel 4x4 (1996 - 2001)

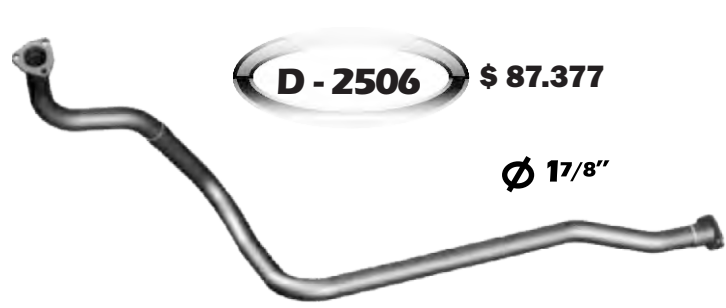

TOYOTA PICK UP HILUX 2.4 - 2.8 Diesel 4x2 (1996 - 2001)



IMPORTADOS



Página 11 - 11



TOYOTA PICK UP HILUX DIESEL 3.0 (C/DOBLE) (2002 -2005)



TOYOTA PICK UP HILUX (2005 - 2015)

